



STATIONARY DAVIT CRANE

# CAPTAIN<sup>®</sup> 4000 SERIES



# CAPTAIN® 5FT40

STATIONARY DAVIT CRANE



## MASSIVE LIFTING POWER with Extensive Reach

The 5FT40 Captain Series stationary davit crane is designed for heavy loads up to 5,500 pounds (2,500 kg) and extended reach (ten feet). It also features a maximum hook height of 12 feet. The integral slewing drive withstands large axial, radial, and moment loads while allowing 360 degrees of smooth and easy rotation. A screw jack comes standard for boom angle adjustments. To ease operation and speed productivity, specify an optional power winch or the optional hydraulic boom angle adjustment—or both! Stainless-steel hardware and corrosion-resistant finishes, including an epoxy-based safety-yellow, resist wear in harsh environments. The 5FT40 is perfect for wind energy, marine, construction, water/wastewater, and oil and gas applications.

### 360° Rotation & Flexible Operation

- Standard with manually operated slewing drive enhances smooth, 360-degree mast rotation under extreme loads for precise load placement
- Standard screw jack for easy boom angle adjustment
- Optional hydraulic boom adjustment package (includes cylinder, hand pump, and control valve) for boom angle adjustments while under load (5FT40H)

### Crane Features & Configurations

- Telescoping boom and adjustable boom angles accommodate a variety of applications
- Choose from manual, drill-drive, or powered winch (electric, pneumatic, or hydraulic motors) operation to accommodate a variety of light or heavy loads and speeds. DC motors and various voltage AC motors available
- Standard recommended rope size is 3/8–1/2 inch based on your lifting requirements
- Configurable to meet European CE and ATEX standards



Product Shown:  
5FT40-E2

## STANDARD CONFIGURATIONS

Series	IMPERIAL/METRIC	
	Description	Up To Capacity
5FT40-M1	Red-enamel crane and ratchet jack with M452B-K spur gear hand winch	5,500 lbs / 2,500 kg
5FT40-M2	Red-enamel crane with 2W40V-BM-K worm gear hand winch and ratchet jack	5,500 lbs / 2,500 kg
5FT40X-M2X	Gray-epoxy crane with 2W40VEGRA-BMX-K worm spur gear hand winch and ratchet jack	5,500 lbs / 2,500 kg
5FT40-E2	Red-enamel crane with 3WG4B-K electric winch and ratchet jack	5,500 lbs / 2,500 kg
5FT40X-E2X	Gray-epoxy crane with 3WG4B-KX electric winch and ratchet jack	5,500 lbs / 2,500 kg
5FT40-E3	4HWF6M electric winch—see tech pages for winch options	5,500 lbs / 2,500 kg
5FT40X-E3	Gray-epoxy 4HWF6M electric winch—see tech pages for winch options	5,500 lbs / 2,500 kg

All configurations available with 5FT40H crane excluding M1

### Durable Construction & Finish

- Boom, mast, and base are fabricated from heavy-duty steel that limits deflection and meets ASTM standards
- Corrosion-resistant finishes and stainless-steel fasteners resist the elements and harsh environments for long service life
- Standard red-enamel finish, optional galvanized, or epoxy (gray, safety-yellow, or custom-color) finishes are available



NOTICE: These products are not for lifting people or things over people.

Refer to technical pages for detailed performance information.

# TECHNICAL DRAWINGS & SPECIFICATIONS

# CAPTAIN® 4000

## STATIONARY DAVIT CRANE

### CONFIGURATIONS

Model	Description	Approx. Ship Wt.	
		(lb)	(kg)
<b>Popular Configurations</b>			
5FT40-M1	up to 5,500 lb capacity with M452B-K spur gear hand winch and black defender-coated ratchet jack—red-enamel crane	1,101	500
5FT40-M2	up to 5,500 lb capacity with 2W40V-BM-K worm gear hand winch and black defender-coated ratchet jack—red-enamel crane	1,146	520
5FT40X-M2X	up to 5,500 lb capacity with 2W40V-BMX-K worm spur gear hand winch and black defender-coated ratchet jack—gray-epoxy crane	1,146	520
5FT40-E2	up to 5,500 lb capacity with 3WG4B-K electric winch and black defender-coated ratchet jack—red-enamel crane	1,216	550
5FT40X-E2X	up to 5,500 lb capacity with 3WG4B-KX electric winch and black defender-coated ratchet jack—gray-epoxy crane	1,216	550
*All configurations available with 5FT40H crane excluding M1			
<b>Crane Only</b>			
5FT40	up to 5,500 lb capacity—black defender-coated ratchet jack—red-enamel crane	1,024	460
5FT40G	up to 5,500 lb capacity—black defender-coated ratchet jack—galvanized crane	1,024	460
5FT40X	up to 5,500 lb capacity—black defender-coated ratchet jack—gray-epoxy crane	1,024	460
5FT40H	up to 5,500 lb capacity—hydraulic jack—red-enamel crane	1,064	480
5FT40HG	up to 5,500 lb capacity—hydraulic jack—galvanized crane	1,064	480
5FT40HX	up to 5,500 lb capacity—hydraulic jack—gray-epoxy crane	1,064	480
<b>Winch Only</b>			
M1	M452B-K spur gear hand winch only—clear zinc coating-(Not available for use with the 5FT40H crane)	91	40
M1X	M452BEGRA-K spur gear hand winch only—gray-epoxy finish-(Not available for use with the 5FT40H crane)	91	40
M2	2W40V-BM-K worm gear hand winch only—powder-coat finish	141	60
M2X	2W40V-BMX-K worm gear hand winch only—gray-epoxy finish	141	60
E2	3WG4B-K electric winch—115/1/60 VAC with 6 ft pendant control—enamel finish	188	85
E2X	3WG4B-KX electric winch—115/1/60 VAC with 6 ft pendant control—gray-epoxy finish	188	85
E2L	3WG4B-KL limit switch ready electric winch—115/1/60 VAC with 6 ft pendant control	187	85
E2LX	3WG4BEGRA-KL limit switch ready electric winch—115/1/60 VAC with 6 ft pendant control—gray-epoxy finish	187	85
E3DL	4HWF6M-KDL limit switch ready electric winch—230/3/60 VAC with control enclosure, 10' pendant—red-enamel finish	476	215
E3DLX	4HWF6MX-KDL limit switch ready electric winch—230/3/60 VAC with control enclosure, 10' pendant—gray-epoxy finish	476	215
E3EL	4HWF6M-KEL limit switch ready electric winch—460/3/60 VAC with control enclosure, 10' pendant—red-enamel finish	476	215
E3ELX	4HWF6MX-KEL limit switch ready electric winch—460/3/60 VAC with control enclosure, 10' pendant—gray-epoxy finish	476	215

### Wire Rope Assemblies—sold separately

Galvanized or stainless steel wire rope assemblies. 316 stainless steel assemblies available—contact factory. For extended wire rope length—contact factory.

Wire Rope Length		Galvanized Aircraft Cable Swivel Hook and Unfinished End		304 Stainless Steel Wire Rope			Galvanized EIPS Steel Wire Rope Carbon Steel Swivel Hook and Unfinished End	
		Swivel Hook and Unfinished End		Carbon Steel Swivel Hook and Unfinished End		Carbon Steel Swivel Hook and Unfinished End		
		3/8" Dia. (9.53 mm)	3/8" Dia. (9.53 mm)	7/16" Dia. (11.11 mm)	1/2" Dia. (12.7 mm)	7/16" Dia. (11.11 mm)	1/2" Dia. (12.7 mm)	
(ft)	(m)	Model No.	Model No.	Model No.	Model No.	Model No.	Model No.	
28	8.5	WA38-28DS	WS38-28DS	WS44-28DS	WS50-28DS	WEG44-28DS	WEG50-28DS	
36	10.9	WA38-36DS	WS38-36DS	WS44-36DS	WS50-36DS	WEG44-36DS	WEG50-36DS	
45	13.7	WA38-45DS	WS38-45DS	WS44-45DS	WS50-45DS	WEG44-45DS	WEG50-45DS	
60	18.2	WA38-60DS	WS38-60DS	WS44-60DS	WS50-60DS	WEG44-60DS	WEG50-60DS	
75	22.8	WA38-75DS	WS38-75DS	WS44-75DS	WS50-75DS	WEG44-75DS	WEG50-75DS	

### PERFORMANCE

#### Captain 4000 5FT40 Series Lift Below Floor<sup>1</sup> Level

Lift Below Floor <sup>2</sup>		Wire Rope Diameter		Wire Rope Length		Winch Configurations Maximum Winch Rating									
						M1*		M2		E2		E3			
(ft)	(m)	(ft)	(m)	(in)	(mm)	(ft)	(m)	(lbs)	(kg)	(lbs)	(kg)	(lbs)	(kg)	(lbs)	(kg)
-4	-1	2	0	3/8"	10	28	8	4,100	1,860	4,100	1,860	4,100	1,860	4,100	1,860
4	1	10	3	3/8"	10	36	10	4,100	1,860	4,100	1,860	3,600	1,630	4,100	1,860
13	3	19	5	3/8"	10	45	13	3,700	1,680	4,100	1,860	3,600	1,630	4,100	1,860
28	8	34	10	3/8"	10	60	18	3,700	1,680	3,700	1,680	3,200	1,450	4,100	1,860
43	13	49	14	3/8"	10	75	22	3,400	1,540	3,400	1,540	3,200	1,450	4,100	1,860
58	17	64	19	3/8"	10	90	27	-	-	3,400	1,540	2,900	1,310	4,100	1,860
88	26	94	28	3/8"	10	120	36	-	-	-	-	2,700	1,220	4,100	1,860
118	35	124	37	3/8"	10	150	45	-	-	-	-	-	-	4,100	1,860
168	51	174	53	3/8"	10	200	60	-	-	-	-	-	-	4,100	1,860
-4	-1	2	0	7/16"	11	28	8	3,900	1,770	3,900	1,770	3,300	1,500	5,500	2,500
4	1	10	3	7/16"	11	36	10	3,400	1,540	3,900	1,770	3,300	1,500	5,500	2,500
13	3	19	5	7/16"	11	45	13	3,400	1,540	3,400	1,540	3,300	1,500	5,500	2,500
28	8	34	10	7/16"	11	60	18	3,000	1,360	3,000	1,360	2,900	1,315	5,500	2,500
43	13	49	14	7/16"	11	75	22	-	-	3,000	1,360	2,600	1,180	5,000	2,270
58	17	64	19	7/16"	11	90	27	-	-	-	-	2,600	1,180	5,000	2,270
88	26	94	28	7/16"	11	120	36	-	-	-	-	-	-	4,600	2,090
118	35	124	37	7/16"	11	150	45	-	-	-	-	-	-	4,200	1,900
168	51	174	53	7/16"	11	200	60	-	-	-	-	-	-	-	-
-4	-1	2	0	1/2"	13	28	8	3,700	1,680	3,700	1,680	3,200	1,450	5,500	2,500
4	1	10	3	1/2"	13	36	10	3,200	1,450	3,700	1,680	3,200	1,450	5,500	2,500
13	3	19	5	1/2"	13	45	13	3,200	1,450	3,200	1,450	2,800	1,270	5,500	2,500
28	8	34	10	1/2"	13	60	18	-	-	-	-	2,800	1,270	5,500	2,500
43	13	49	14	1/2"	13	75	22	-	-	-	-	-	-	5,000	2,270
58	17	64	19	1/2"	13	90	27	-	-	-	-	-	-	5,000	2,270
88	26	94	28	1/2"	13	120	36	-	-	-	-	-	-	4,500	2,040
118	35	124	37	1/2"	13	150	45	-	-	-	-	-	-	-	-
168	51	174	53	1/2"	13	200	60	-	-	-	-	-	-	-	-

<sup>1</sup>Performance characteristics are for standard products. Non-standard products may vary from the original design. Contact Thern, Inc. for this information.

<sup>2</sup>Lift below floor level varies depending on boom position and base configuration. For longer lifts, please contact factory.

\*Not available for use with the 5FT40H crane.

#### Winch Configurations

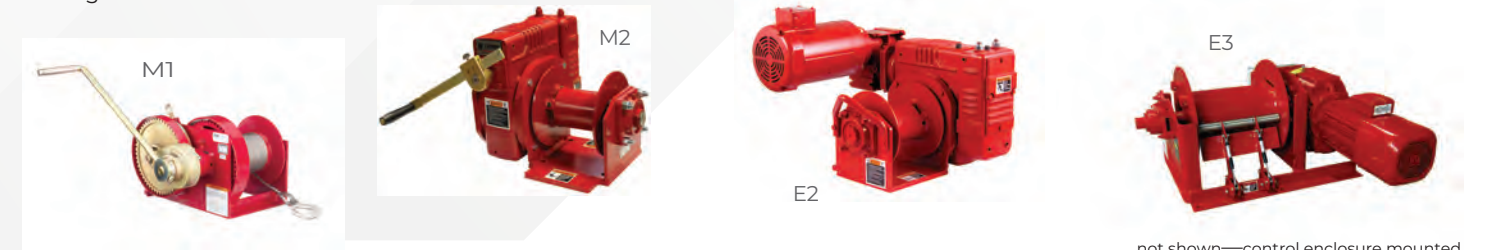

not shown—control enclosure mounted

## Captain 4000 Performance Ratings

	Boom Position	1st Layer Load Rating		Hook Reach		Hook Height**	
		(lb)	(kg)	(in)	(mm)	(in)	(mm)
BLUE RANGE	A-1	4,800	2,180	77	1,955	68	1,727
	A-2	4,100	1,860	92	2,337	68	1,727
	A-3	3,500	1,590	107	2,718	68	1,727
	A-4	3,000	1,360	122	3,099	68	1,727
GREEN RANGE	B-1	5,500	2,500	69	1,753	102	2,591
	B-2	4,600	2,090	82	2,083	108	2,743
	B-3	4,000	1,810	96	2,438	115	2,921
	B-4	3,300	1,500	109	2,768	121	3,073
YELLOW RANGE	C-1	5,500	2,500	55	1,397	122	3,099
	C-2	4,600	2,090	66	1,677	132	3,353
	C-3	4,000	1,810	77	1,955	143	3,632
	C-4	3,300	1,500	87	2,209	153	3,886

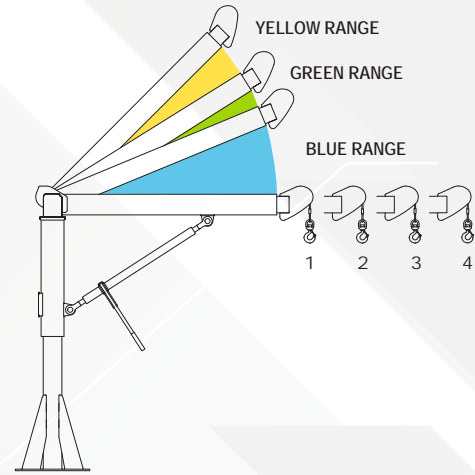

5FT40H

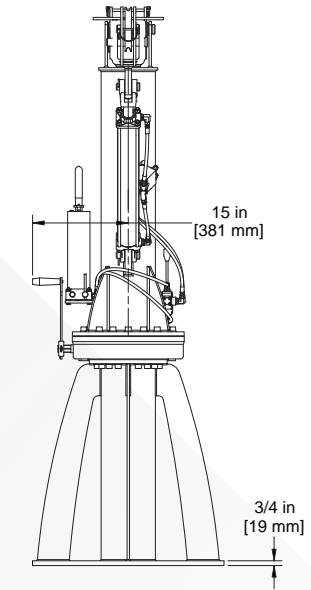
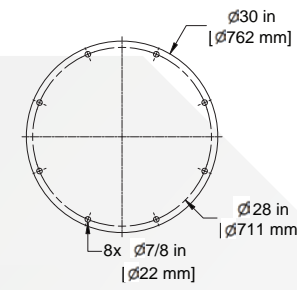

Dimensions are for reference only and subject to change without notice.

\*\*Crane maximum load rating. Load rating may decrease as layers of rope wind onto the winch-drum. Refer to winch-specific information

5FT40

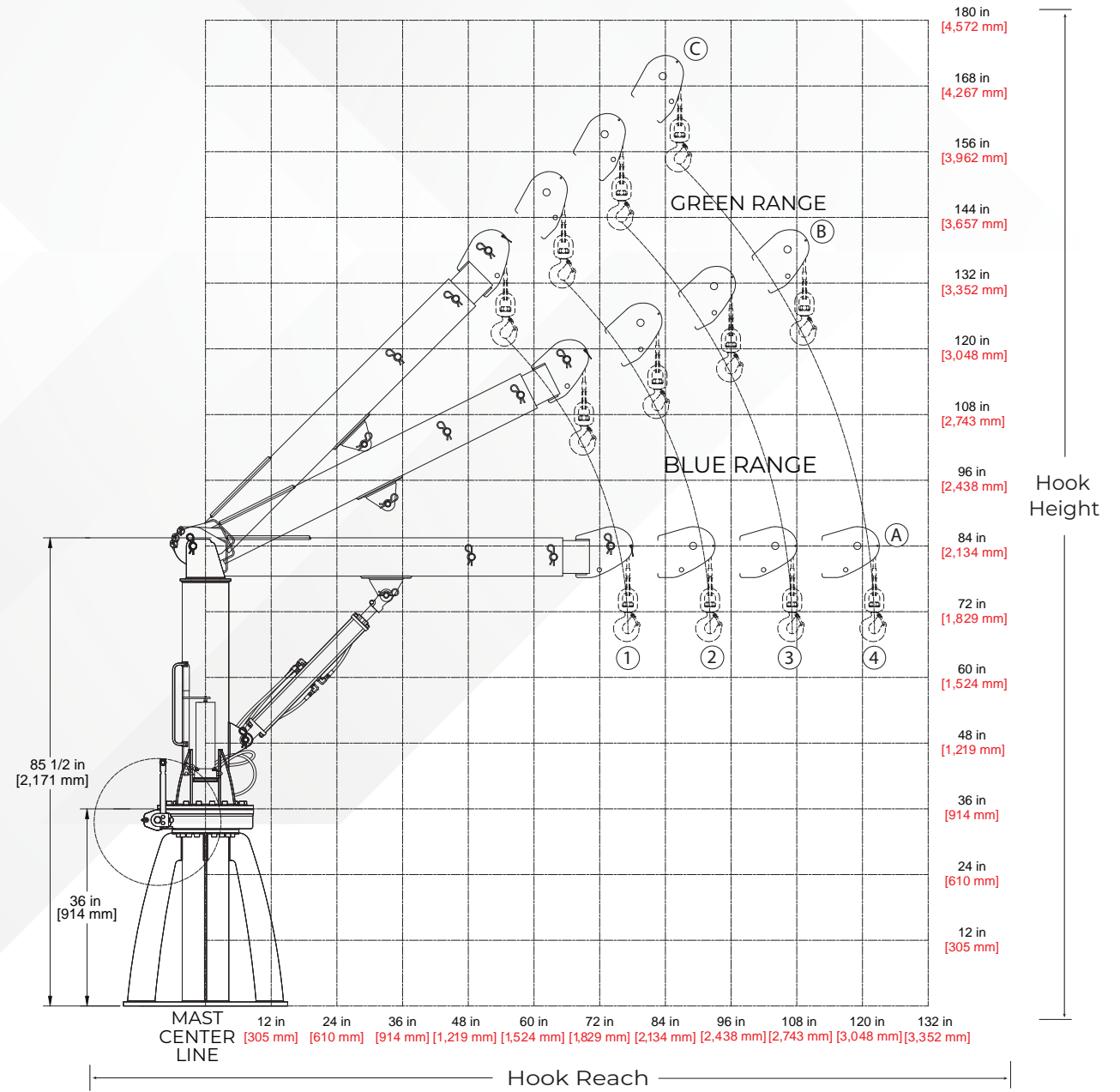
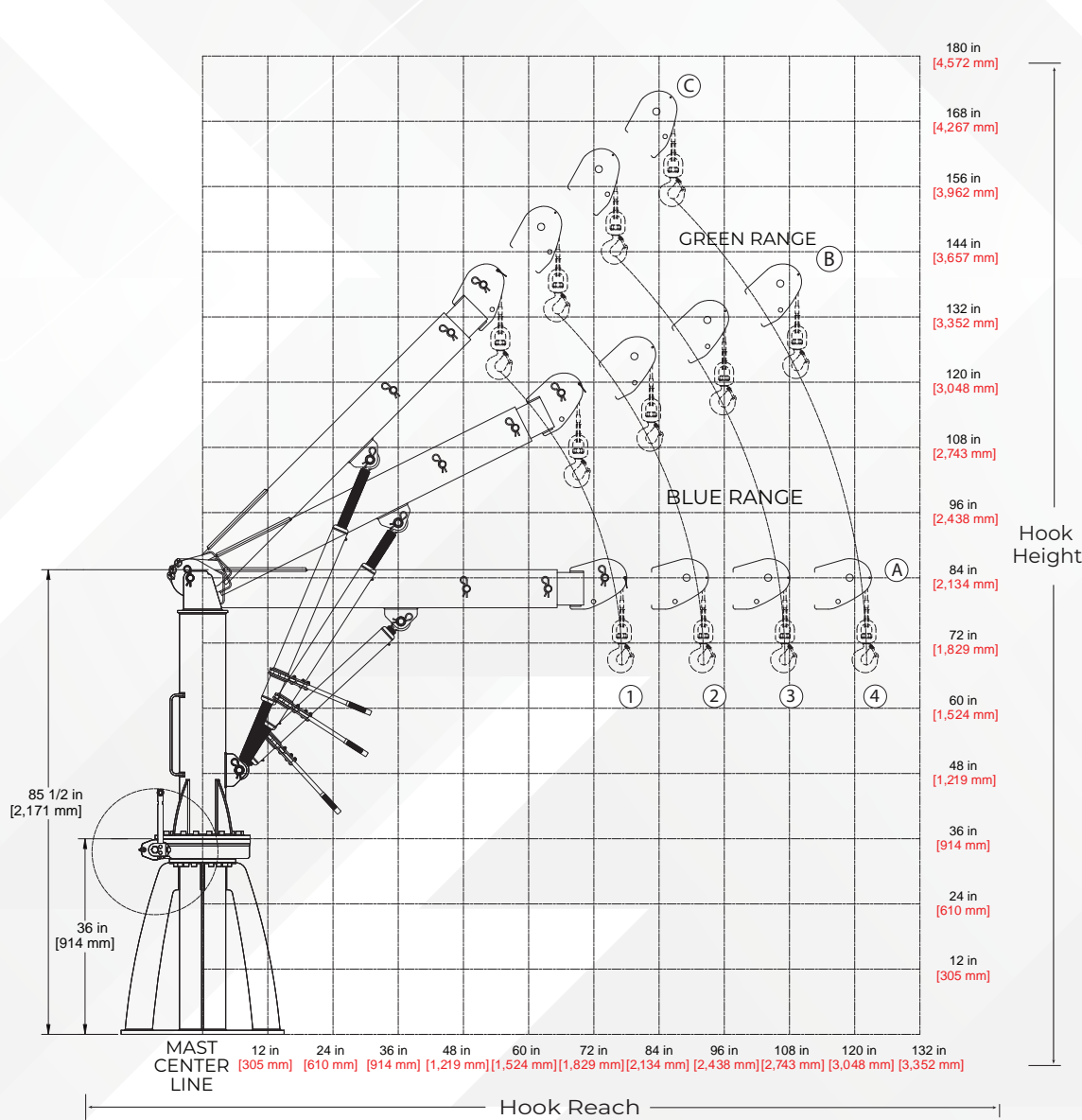
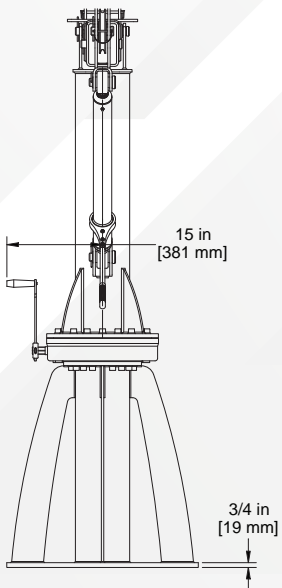
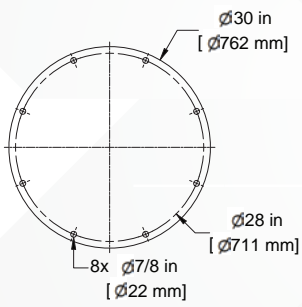

# CRANE

## OPTIONS & ACCESSORIES



Base Anchor Kit	
Model	Description
AN50A-5	(4) Hilti® zinc-plated steel fasteners 1/2" X 5.50" STL (5PA5, 5PF5, and 5PT5 cranes)
AN50A-5S	(4) Hilti® 304 stainless-steel fasteners 1/2" X 5.50" SST304 (5PA5, 5PF5, and 5PT5 cranes)
AN50A-5S316	(4) Hilti® 316 stainless-steel fasteners 1/2" X 5.50" SST316 (5PA5, 5PF5, and 5PT5 cranes)
AN62A-6	(4) Hilti® zinc-plated steel fasteners 5/8" X 6.00" STL (5PA10, 5PT10, 5PT20, and 5FT20 cranes)
AN62A-6S	(4) Hilti® 304 stainless-steel fasteners 5/8" X 6.00" SST304 (5PA10, 5PT10, 5PT20, and 5FT20 cranes)
AN62A-6S316	(4) Hilti® 316 stainless-steel fasteners 5/8" X 6.00" SST316 (5PA10, 5PT10, 5PT20, and 5FT20 cranes)

Rotational Lock	
Model	Description
5P5LCK	For pedestal, wall, and flush-mount bases, 316 stainless steel—available for use 5PA5, 5PF5, and 5PT5

Cable Spooler	
Model	Description
RW50	316 stainless-steel reel winds up wire rope when detached from crane

Wire Rope Keeper	
Model	Description
RK19-25S	304 Stainless-steel bracket holds free end of the wire rope when detached from the crane
RK19-25S316	316 Stainless-steel bracket holds free end of the wire rope when detached from the crane

Roller Ball Bearing for 5PT10 Series Crane	
Model	Description
5PT10BRG	Red electrostatic, powder-coat paint finish
5PT10BRG-S	304 stainless-steel, electro-polished finish for added protection against corrosion
5PT10BRG-S316	Stainless-steel, electro-polished finish for maximum protection against corrosion
5PT10BRG-SS	304 stainless steel, for use with stainless-steel base only
5PT10BRG-SS316	316 stainless steel, for use with stainless-steel base only

Roller Ball Bearing for 5PT20 Series Crane	
Model	Description
5PT20BRG	Red electrostatic, powder-coat paint finish
5PT20BRG-S	304 stainless-steel, electro-polished finish for added protection against corrosion
5PT20BRG-S316	Stainless-steel, electro-polished finish for maximum protection against corrosion
5PT20BRG-SS	304 stainless steel, for use with stainless-steel base only
5PT20BRG-SS316	316 stainless steel, for use with stainless-steel base only

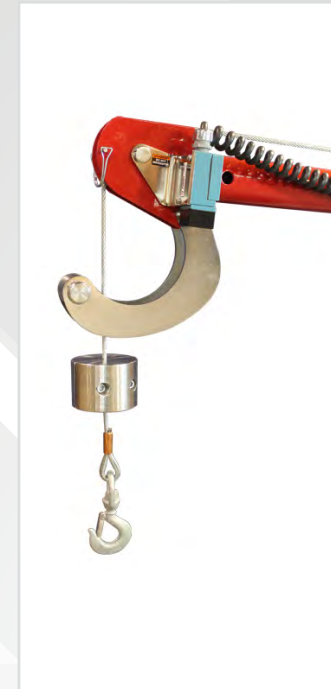

Limit Switch Ready Winch Options	
Model	Description
NOTE: Limit switch winch option requires purchase of Limit Switch and Headache Ball (sold separately)	
<b>For 5PF5, 5PA5, 5PA10, 5PT5, 5PT10, 5PT20 Series Cranes (sold separately)</b>	
E2L (5PA5, 5PA10)	4WP2V-KL electric winch – 115/1/60 VAC with 6 ft pendant control – enamel
E2LX (5PA5, 5PA10)	4WP2VEGRA-KL electric winch – 115/1/60 VAC with 6 ft pendant control – epoxy gray
E4L	4777-KL electric winch – 115/1/60 VAC with 6 ft pendant control – enamel
E4LX	4777EGRA-KL electric winch – 115/1/60 VAC with 6 ft pendant control – epoxy gray
E4DCL	4777DC-KL electric winch – 12 volt DC with 10 ft pendant control – enamel
E4DCLX	4777DCEGRA-KL electric winch – 12 volt DC with 10 ft pendant control – epoxy gray
<b>For 5FT20 Series Crane Only (sold separately)</b>	
E2L	4WP2-KL electric winch – 115/1/60 VAC with 6 ft pendant control – enamel
E2LX	4WP2EGRA-KL electric winch – 115/1/60 VAC with 6 ft pendant control – epoxy gray
E4L	4771-KL electric winch – 115/1/60 VAC with 6 ft pendant control – enamel finish
E4LX	4771EGRA-KL electric winch – 115/1/60 VAC with 6 ft pendant control – gray-epoxy finish
E4DCL	E4DCL 4771DC-KL electric winch – 12 volt DC with 10 ft pendant control – enamel finish
E4DCLX	4771DCEGRA-KL electric winch – 12 volt DC with 10 ft pendant control – gray-epoxy finish
<b>For 5PT30, 5FT25, 5FT40 Series Crane Only (sold separately)</b>	
E2L	3WG4B-KL electric winch - 115/1/160 VAC with 6 ft pendant control – enamel finish
E2LX	3WG4BEGRA-KL electric winch - 115/1/160 VAC with 6 ft pendant control – epoxy gray finish
E2TL	3WG4BMT-K electric winch - 115/1/160 VAC with 6 ft pendant control – enamel finish (Unavailable for use with 5FT40)
E2TLX	3WG4MTX-KL electric winch - 115/1/160 VAC with 6 ft pendant control – epoxy gray finish

Drill Drive Kit	
Model	Description
ED330-DW11	120 VAC, 11-amp, 330 rpm drill motor to power drive the hand winch. Only available for cranes configured with the M2 winch option. Includes 1-1/8" hex drive socket
ED300-DW06	Cordless drill kit, 60 V brushless motor, 300 rpm drill motor to power drive the M2 hand winch option. Includes 1-1/8" hex drive socket
ED400-DW09	Heavy-duty cordless drill kit, 60 V brushless motor, 400 rpm drill motor to power drive the M2 hand winch option. Includes 1-1/8" hex drive socket

Headache Ball	
Model	Description
HB10-12-25	Red enamel painted 10 lb fits 1/8" to 1/4" rope
HB10-25-38	Red enamel painted 10 lb fits 1/4" to 3/8" rope
HB10S-12-25	Stainless-steel 10 lb fits 1/8" to 1/4" rope
HB10S-25-38	Stainless-steel 10 lb fits 1/4" to 3/8" rope
HB10S-44-50	Stainless-steel 10 lb fits 7/16" to 1/2" rope

Base Extension	
Model	Description
5BE5-15	Available on 5PF5, 5PT5, 5PT10, and 5PT20 with powder-coat, galvanized, 304 & 316 stainless-steel, and epoxy finishes
5BE10-15	
5BE20-15	