

Computer Station

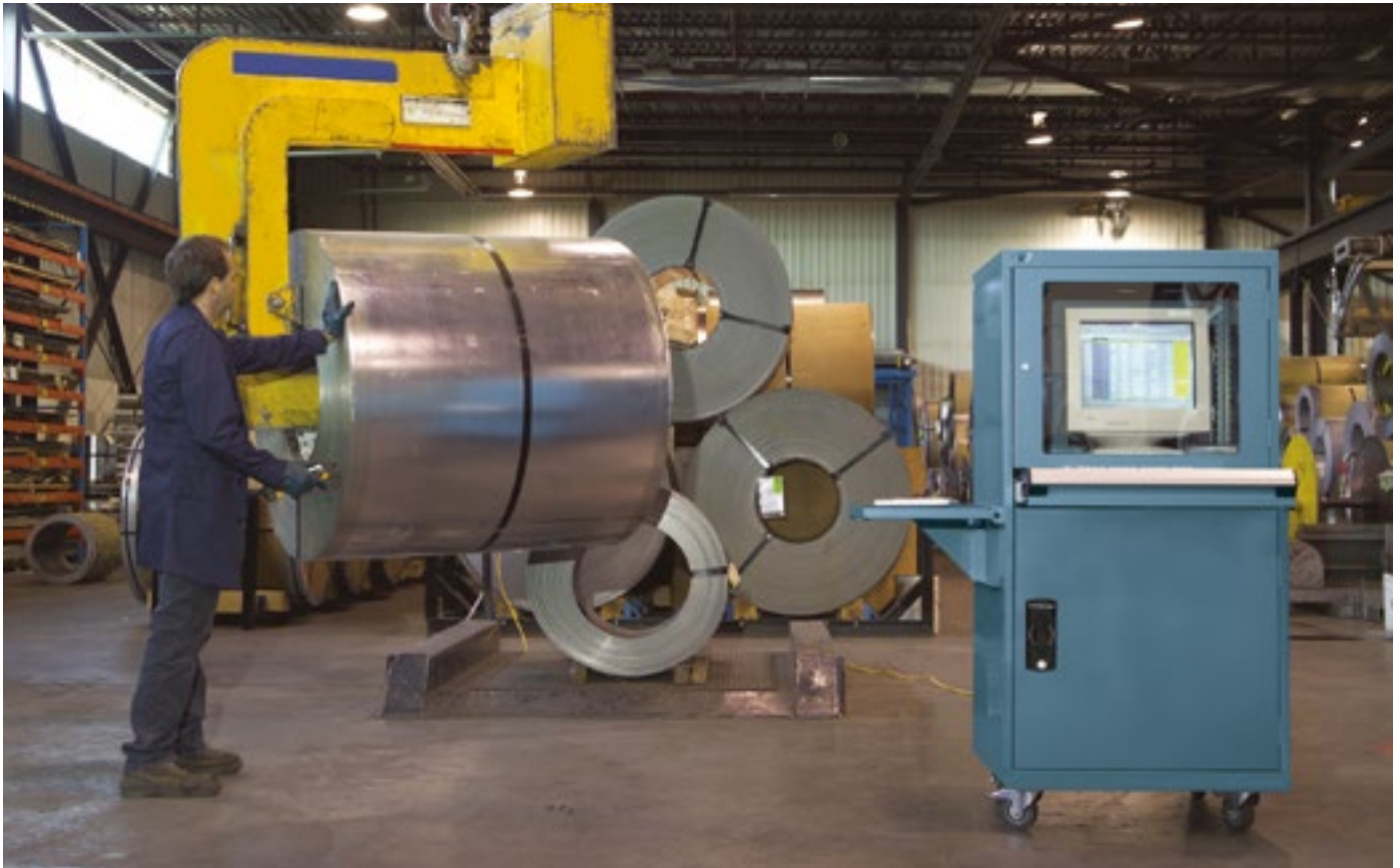

COMPUTER STATION

With our vast range of products and accessories, you can create a customized computer station that is tailored to your needs. Whether you need your computer station equipped with a worksurface, extra storage, or even a basic inquiry station, we have the solution you need!

Our products are designed for industrial use (production floor, packing, maintenance and repair, machine shop, etc.), but with their attractive design, they can also be used in office environments (laboratories, electronic and computer environments, etc.).

Index	Page(s)
Computer Station	190 - 201
Proposals	191 - 195
Components	196 - 201

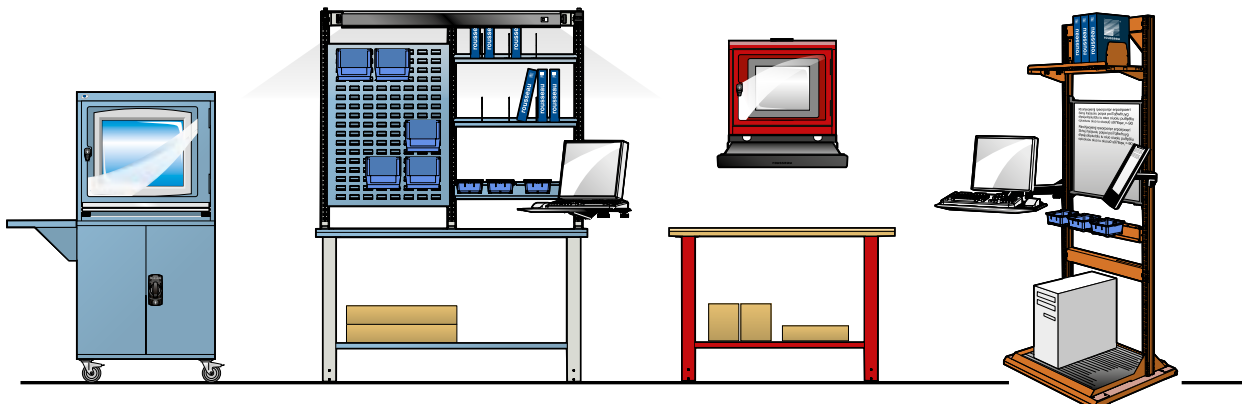

Computer Cabinet

The Rousseau computer cabinet ensures a protection of the computer. The fan with filter will promote proper air circulation.

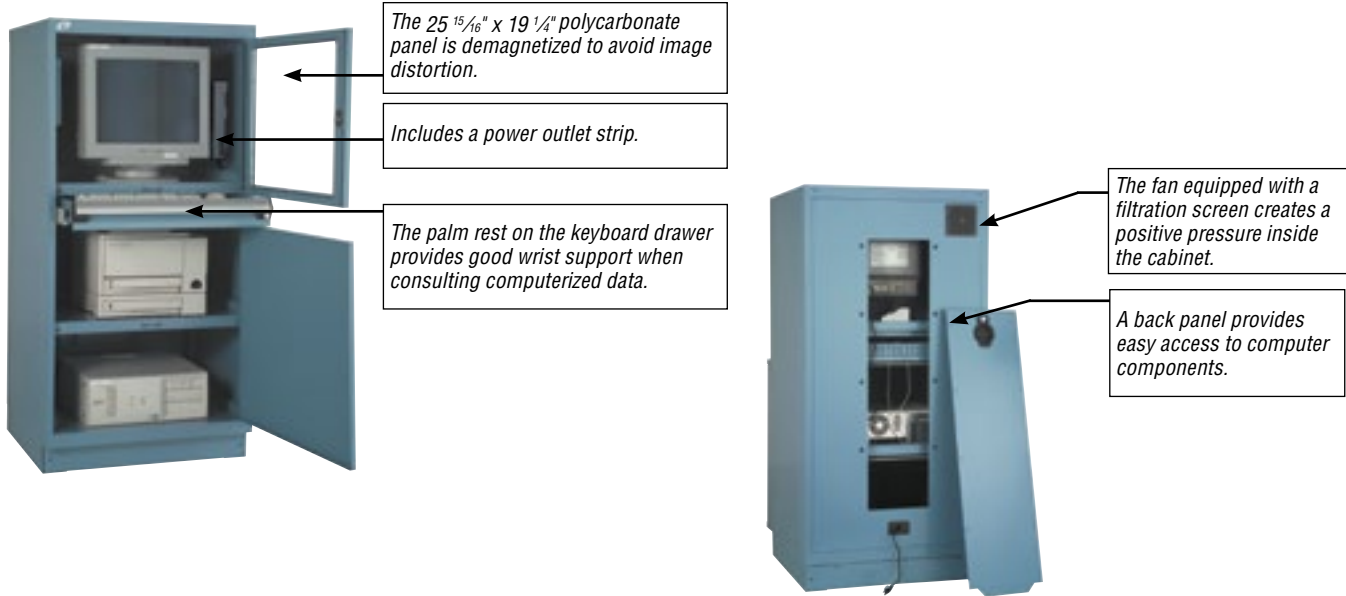

Computer Cabinet with Adjustable Shelf

Stationary



R5JDG-5801

- 1 computer cabinet housing with back access panel RD31-302758L3
- 1 adjustable shelf (for monitor) RB21-3027
- 1 keyboard drawer RF31-302704L3
- 1 keyboard riser RD40-301204
- 1 adjustable shelf (for printer) RB21-3027
- 1 bottom shelf (for computer) RB25-3027
- 1 polycarbonate door for screen RD51-3022L3
- 1 single integrated door RB62-3028L3

Stationary Cabinet Includes:

- 1 recessed base (front access) RA55-302704
- 1 back cover plate RA56-3004

Mobile Cabinet Includes:

- 2-4" rigid casters RB81-01
- 2-4" swivel casters with total-lock brake system RB81-03

Product #	W x D x H
R5JDG-5801	30" x 27" x 62"
R5JDG-5821	30" x 27" x 63 1/4"

Mobile



R5JDG-5821



Proposals

Computer Cabinet with Roll-Out Shelf

Stationary



R5JDG-5815

- 1 computer cabinet housing with back access panel RD31-302758L3
- 1 adjustable shelf (for monitor) RB21-3027
- 1 keyboard drawer RF31-302704L3
- 1 keyboard riser RD40-301204
- 1 front access roll-out shelf (for printer) RF55-3027
- 1 bottom shelf (for computer) RB25-3027
- 1 polycarbonate door for screen RD51-3022L3
- 1 single integrated door RB62-3028L3

Stationary Model Includes :

- 1 recessed base (front access) RA55-302704
- 1 back cover plate RA56-3004

Mobile Model Includes :

- 2-4" rigid casters RB81-01
- 2-4" swivel casters with total-lock brake system RB81-03

Product #	W x D x H
R5JDG-5815	30" x 27" x 62"
R5JDG-5837	30" x 27" x 63 1/4"

Mobile



R5JDG-5837

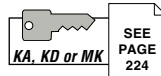

Computer Cabinet with Two Roll-Out Shelves

Stationary



R5JDG-5819

- 1 computer cabinet housing with back access panel RD31-302758L3
- 1 adjustable shelf (for monitor) RB21-3027
- 1 keyboard drawer RF31-302704L3
- 1 keyboard riser RD40-301204
- 1 front access roll-out shelf (for printer) RF55-3027
- 1 front access roll-out shelf (for computer) RF55-3027
- 1 polycarbonate door for screen RD51-3022L3
- 1 single integrated door RB62-3028L3

Stationary Cabinet Includes :

- 1 recessed base (front access) RA55-302704
- 1 back cover plate RA56-3004

Mobile Cabinet Includes :

- 2-4" rigid casters RB81-01
- 2-4" swivel casters with total-lock brake system RB81-03

Product #	W x D x H
R5JDG-5819	30" x 27" x 62"
R5JDG-5839	30" x 27" x 63 1/4"

Mobile



R5JDG-5839



Smart Computer Cabinet

Our smart computer cabinet offers an alternative to conventional computer cabinets. You have the choice of a cabinet with or without doors, and with or without a keyboard tray.

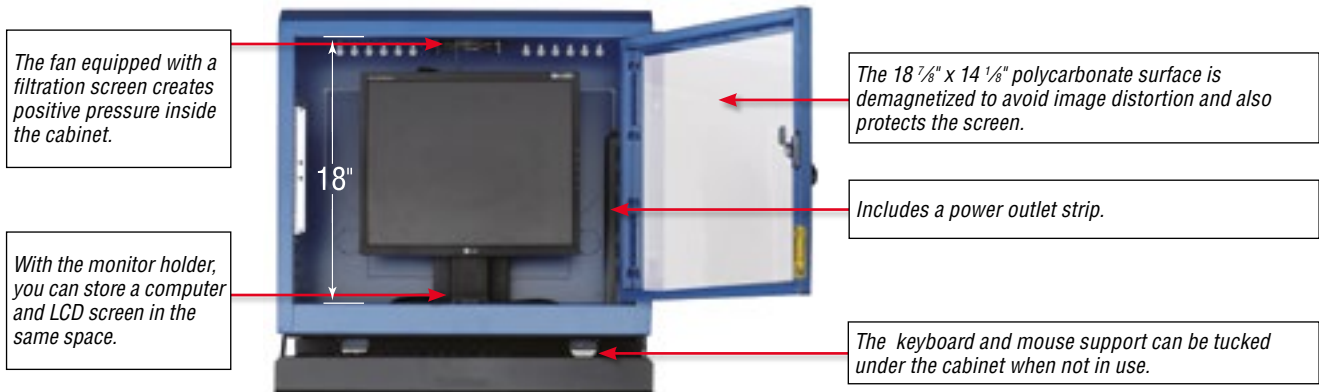

Smart Computer Cabinet with Choice of Configurations

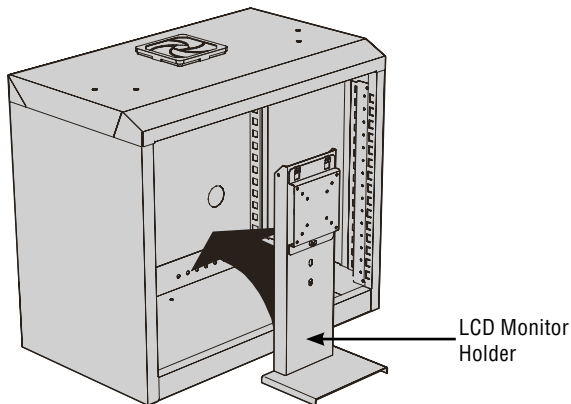

Cabinet dimensions : 24" W x 14" D x 21" H;
 Polycarbonate surface dimensions : 18 7/8" W x 14 7/8" H;
 Useable support surface : 22 1/2" W x 14 1/2" D.

Product #	Type
R5MCA-2450	Wall-mounted cabinet only
R5MCA-2451	Wall-mounted cabinet with polycarbonate door
R5MCA-2452	Wall-mounted cabinet with keyboard and mouse support
R5MCA-2453	Wall-mounted cabinet with polycarbonate door and keyboard and mouse support
R5MCA-2454	Wall-mounted cabinet with flipper door and laptop support

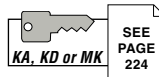

NOTE The wall-mounted cabinet includes the LCD monitor holder.



The RD47 support can also be installed under a RD02 cabinet to use a laptop.

Multi-Purpose Stand

Here are some of our different multi-purpose stand options. Please see the "Work Center - WS/WM" section for the different accessories offered.

SEE
PAGES
125-133

Off-Centered Model

WMA4061

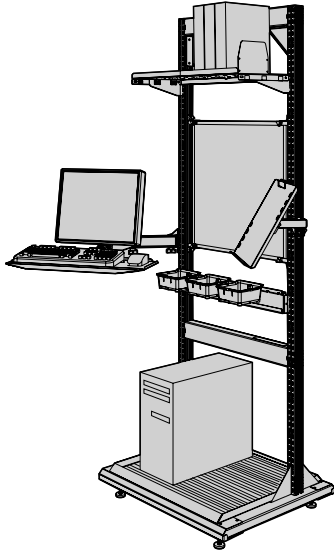

1 - 84" high off-center WM stand	WMA4001
1 LCD monitor and keyboard holder	WM65-02B
1 document holder with arm	WM70-01
1 tackboard and marker panel	WM54-2424
1 panel bracket kit	WM50-01
1 tiltable shelf	WM20-2812
2 partial dividers	SH52-1206
1 plastic bin rail	WM28-2801
3 plastic bins	RG20-060603
1 bottom shelf with ribbed mat	WM83-282702

Product #	W x D x H
WMA4061	32" x 27" x 85"

Centered Model

WMA3051

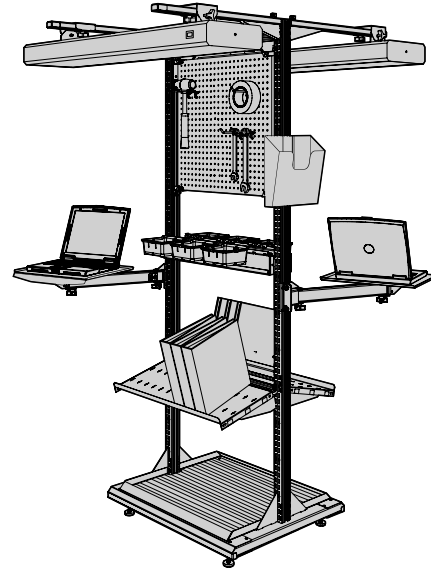

1 - 84" high centered WM stand	WMA3001
2 trays for laptop	WM62-01A
2 perforated panels	WM53-2424
1 panel bracket kit	WM50-01
1 document holder	WM90-01
2 plastic bin rails	WM28-2801
6 plastic bins	RG20-060603
2 tiltable shelves	WM20-2812
1 pack of 10 hooks for perforated panel	WM9H-03
2 pairs of cantilever overhead supports	WM18-26
2 overhead workstation lights	WM45-48T8-28
1 bottom shelf with ribbed mat	WM83-282701

Product #	W x D x H
WMA3051	32" x 27" x 85"

Components

Computer Cabinet

Computer Cabinet Housing with Back Panel

RD31

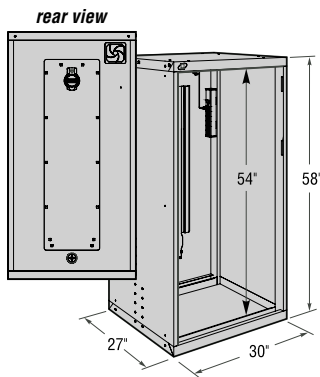

Equipped with ventilator with filtration screen;
Includes power outlet strip;
Back access panel provides easy access to computer components. Includes a lock;
Space to run wires;
Compatible with 4" and 6" casters;
Compatible with RA53 forklift base, the RA55 recessed base and base risers RB94 and RB95;
Note : It is strongly suggested to order a base (RA55, RB94 or RB95) for upright positions or for taller people.

Product #	W x D x H
RD31-302758L3	30" x 27" x 58"

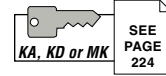

Recessed Base

RA55

Riser Base

RB95

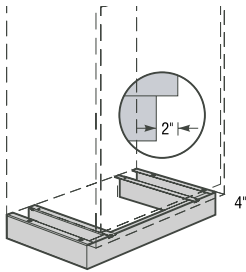

Designed to raise the height of a cabinet by 4";
Designed for moving the cabinet from the front with a forklift or pallet-jack;
Includes a removable cover plate at the front for aesthetics and in order to move the cabinet from the front;
Compatible with the RA56 rear base cover plate, offered as an option. Front cover plate included;
Front cover plate is on a straight angle to facilitate cleaning floors;
Designed to allow user to anchor the cabinet to the floor;
Compatible with leveling glides RA74;
Not compatible with casters.

Product #	W x D x H
RA55-302704	30" x 27" x 4"

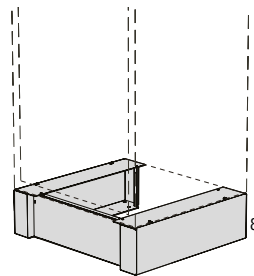

Used to raise the height of a cabinet by 8";
Provides improved ergonomics for taller people;
Installs directly under the cabinet;
Used to move the cabinet from the front with a forklift;
Compatible with leveling glides (RA74);
Compatible with the RB98 rear base cover plate, offered as an option. Front cover plate included;
Not compatible with casters.

Product #	W x D x H
RB95-302708	30" x 27" x 8"

Base Riser for Mobile Cabinet

RB94

Cover Plate

RA56 / RB98

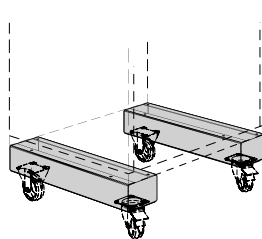

Designed to raise the height of a mobile cabinet by 4";
Allows medium height and tall people to be comfortable when working at the cabinet;
Installs directly under cabinet;
Compatible with 4" and 6" high casters.

Product #	D x H
RB94-2704	27" x 4"

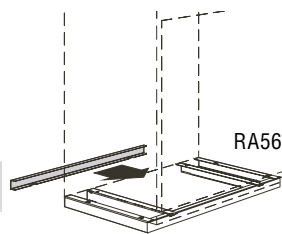

RA56 : Closes off the back of 4" recessed bases (RA55);
RB98 : Closes off the back of riser base (RB95).

Product #	W x H	For
RA56-3004	30" x 4"	RA55
RB98-3008	30" x 8"	RB95

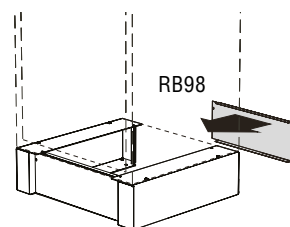

Leveling Glide Kit

RA74

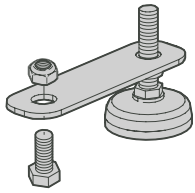

Sold in kits of 4;
Installs directly under the cabinet, without base, or under the RB95 riser base;
Serves to adjust the height (1 1/8" to 2") of cabinet housing on uneven floor surfaces.

Product #
RA74-01

4" and 6" Casters

RB81 / RB84

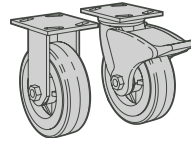

Sold in pairs;

Choice of 3 types of casters : rigid, swivel, swivel with total-lock brake system (on wheel and swivel);

4" casters: total height of 5 1/4";

6" casters: total height of 7 1/2";

Polyurethane casters (do not mark floors). Superior quality industrial casters;

The casters install directly under cabinet (without base); they are also compatible with the base riser (RB94) for mobile cabinets.

Product #	Height	Type of caster
RB81-01	4"	Rigid
RB81-02	4"	Swivel
RB81-03	4"	Swivel with total-lock brake system
RB84-01	6"	Rigid
RB84-02	6"	Swivel
RB84-03	6"	Swivel with total-lock brake system

Keyboard Drawer

RF31

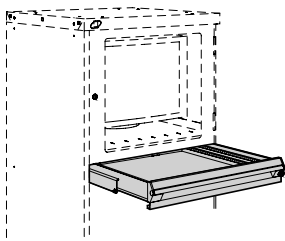

Possible to store a standard (12" deep) three-ring binder behind keyboard;

Compartments can be created by adding partitions, dividers and plastic bins;

Standard lock included;

Note : It is strongly recommended to order the RD40 keyboard riser to place keyboard and mouse in an ergonomic position.

SEE PAGES 185-188

Product # **W x D x H**
RF31-302704L3 30" x 27" x 4"

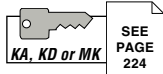

Keyboard Riser

RD40

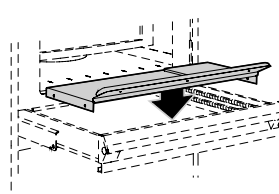

Allows user to place keyboard and mouse in an ergonomic position;

Equipped with wrist rest;

Leaves enough room to store a standard (12" deep) three-ring binder behind keyboard;

Leaves enough room to add compartments by adding partitions, dividers and plastic bins.

Product # **W x D x H**
RD40-301204 30" x 12" x 4"

Roll-Out Shelf for Integrated Door

RF55

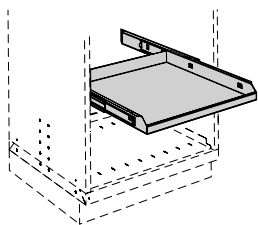

Allows storage of bulky items;
Compatible with the RB62 integrated door;

65% extension;

175 lb. capacity;

Painted steel with back and side edges;

Full access to contents.

Product # **W x D**
RF55-3027 30" x 27"

Adjustable Shelf

RB21

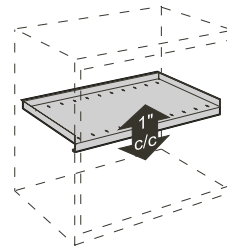

Perfect for storing bulky items;

Has edges along the sides and back to prevent items from falling into the bottom of the cabinet;

Adjustable every 1" c/c;

Up to 400 lb. capacity, evenly distributed load.

Product # **W x D**
RB21-3027 30" x 27"

Bottom Shelf for Cabinet

RB25

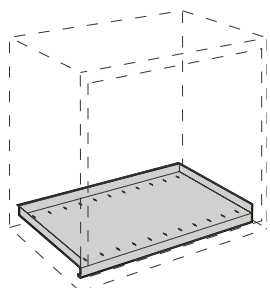

Perfect for storing bulky items;

Has edges along the sides and back to prevent items from falling into the bottom of the cabinet;

Up to 400 lb. capacity, evenly distributed load.

Product # **W x D**
RB25-3027 30" x 27"



Components

Polycarbonate Door for Screen **RD51**

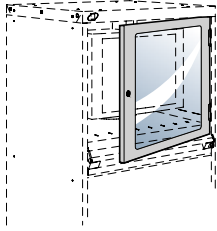

Demagnetized polycarbonate panel
24 15/16" W x 19 1/4" H to avoid image distortion;
Factory installed on RD31 cabinet housings;
Standard lock included.

Product #	W x H
RD51-3022L3	30" x 22"



Single Integrated Door, Solid or Polycarbonate **RB62 / RB61**

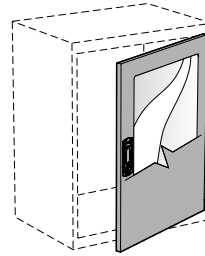

Single Integrated door : RB62;
Single Integrated polycarbonate door : RB61;
Compatible with the bottom shelf (RB25), the
adjustable shelf (RB21) and the roll-out shelf
(RF55);

Opens 180° for full access to items stored
inside;
Factory installed on RD61 cabinet housings ;
Standard lock included.

Product #	W x H
RB62-3028L3	30" x 28"
RB61-3028L3	30" x 28"

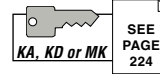

Foldaway Shelf **RC00**

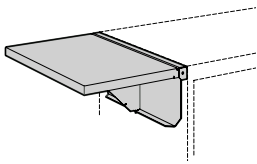

50 lb. capacity (evenly distributed load);
Rubber mat surface for added protection;
RC01 side and back stops can be installed as
an option.

Product #	W x D
RC00-152701	15" x 27"

Side and Back Stops for Foldaway Shelf **RC01**

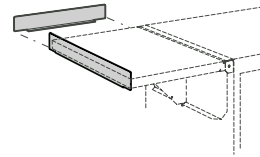

Use the 15" stop for the front or back of
the shelf;

Use the 27" stop for the sides;
Height : 1".

Product #	Width
RC01-15	15"
RC01-27	27"

Accessories Underneath the Worksurface

Sliding Keyboard Tray **WS90-01**

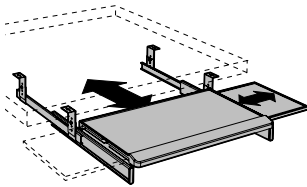

May be mounted on all surfaces;
Mouse tray slides to the left or right side,
as needed;
Usable area : 8 1/2" x 20 1/2";
Mouse tray : 9 3/8" x 9 1/8".

Product #	Color
WS90-01	Black

CPU Support **WS92**



May be mounted on all surfaces;
Handle allows width of plastic side support to
be adjusted;
Adjustments accommodate computers with
dimensions of 3 1/2" to 9 1/4" width by 12 1/2" to
22 1/2" height;
Width : 8 3/8" to 11 1/2";
Depth : 6 3/4" (8 1/2" with handle);
Height : 18" to 26".

Product #	Color
WS92-01	Black

Adjustable Keyboard Tray **WS90-02**

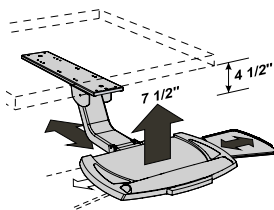

Support with articulating arm designed for
use in the sit/stand position;
May be mounted on all surfaces;

Includes :
- mouse tray, slides to the left or right
side, as needed
- ergonomic palm rest

Slides under the work surface for storage.
Sturdy construction;
Usable area : 9 1/2" x 20 1/2";
Mouse tray : 9 3/8" x 9".

Product #	Color
WS90-02	Black

Computer Supports for Work Surfaces

All models presented includes these specifications :

Installs on the work surface with the RC68 or RC69 finishing panel for computer support;

Compatible with the following work surface : WS14, RC35, RC36 and RC37;

Each support comes with an 18" high post allowing a custom fit for each user;

The work surface shall extend beyond the rear by 1 1/2";

Articulating arms, adaptors and trays are painted in black;

Does not install directly on the housing.

LCD Monitor Support



Designed to support most LCD monitors up to 21" available on the market;

Includes one or two double articulating arms; Positioning of monitor anchors comply with VESA 75 and 100 standards;

The double articulating arm allows for increased adjustability;

The screen can also be tilted for better ergonomics;

Single or double LCD monitor support available for order.

Product #	For
RC59-03	Single screen
RC59-04	Double screen

Laptop Support



Designed to hold a laptop computer, papers, binders or any other object;

Usable tray surface : 14" W x 12" D;

Includes one double articulating arm and the tray;

The double articulating arm allows for increased adjustability;

The tray can also be tilted for better ergonomics.

Product #
RC59-42

LCD Monitor, Keyboard and Mouse Support



Designed to hold a computer monitor, keyboard and mouse;

Usable surface of the keyboard and mouse tray: 23 5/8" W x 8 1/2" D;

Includes one articulating arm and the tray;

Positioning of monitor anchors comply with VESA 75 and 100 standards;

Can support most LCD monitors up to 21" available on the market;

Tray and screen can also be tilted for better ergonomics.

Product #
RC59-21

Electronic Tablet Support



Designed to support most electronic tablets on the market;

Includes one double articulating arm and the tablet support;

Safely holds the tablet in place;

The holding clamps and back of the support are rubberized to help prevent scratches and damage to the device;

The double articulating arm allows for increased adjustability;

The support can also be tilted for better ergonomics.

Size of compatible tablet:

– small: 7 5/8" to 10" wide

– large: 9 7/8" to 12 1/4" wide.

Product #	Version
RC59-62-01	Small
RC59-62-02	Large

Components

Computer Supports for Multi-Purpose Frames and Wall Mounted Applications

Standard Monitor Tray

WM62 / WM64

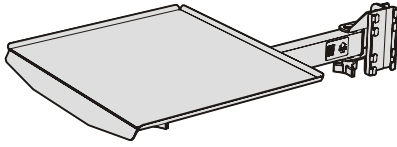

May be used to hold a computer monitor, laptop computer, electronic device or any other object;
 Usable tray space : 16" W x 13 7/8" D;
 Includes one 18" heavy-duty arm with single or double articulation and a non-slip rubber mat;
 The double articulated model allows for increased adjusting possibilities;
 Compatible with the WM63 keyboard and mouse tray;
 50 lb capacity (wall mounted version: the wall and wall anchoring must be strong enough);
 Color : Black;
 Wall anchoring not included for the wall mounted model.

Product #	Articulating Arm	Model
WM62-01A	Single	For WM11 frame
WM62-02A	Double	For WM11 frame
WM64-01A	Single	Wall mounted
WM64-02A	Double	Wall mounted



Keyboard and Mouse Tray

WM63

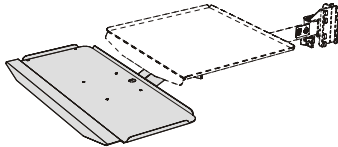

Installs on the WM62 and WM64 monitor tray with arm;
 Color : Black;
 Usable tray space : 23 11/16" W x 8 1/2" D.

Product #
WM63-2402



LCD Monitor Holder

WM65 / WM66

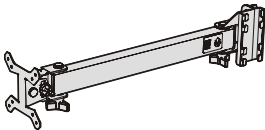

Can be used to hold the majority of LCD monitors on the market;
 Screen anchor support respects VESA 75 & 100 standards;
 Possible to tilt the screen;
 Color : Black;
 Note : Not compatible with the keyboard tray.

Product #	Articulating Arm	Model
WM65-01A	Single	For WM11 frame
WM65-02A	Double	For WM11 frame
WM66-01A	Single	Wall mounted
WM66-02A	Double	Wall mounted



LCD Monitor and Keyboard Holder

WM65 / WM66

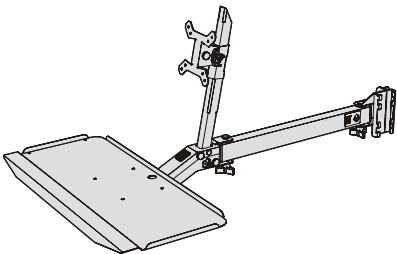

Can be used to hold the majority of LCD monitors on the market;
 Screen anchor support respects VESA 75 & 100 standards;
 Includes a keyboard holder, usable surface is 23 11/16" W x 8 1/2" D;
 Color : Black;
 Screen can be adjusted in height, and can also be tilted.

Product #	Articulating Arm	Model
WM65-01B	Single	For WM11 frame
WM65-02B	Double	For WM11 frame
WM66-01B	Single	Wall mounted
WM66-02B	Double	Wall mounted

Wall Mounted

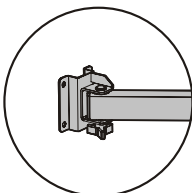

For WM11 Frame

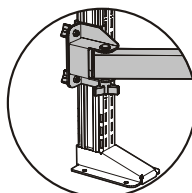

Double Articulating Arm

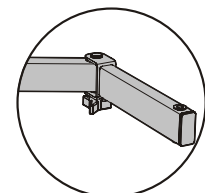

LCD Monitor Support



Designed to support most LCD monitors up to 21" available on the market;
Includes one double articulating arm;
Positioning of monitor anchors comply with VESA 75 and 100 standards;
The double articulating arm allows for increased adjustability;
The screen can also be tilted for better ergonomics;
Color: black;
Wall anchoring kit not included.

Product #	Model
WM05-03	For WM11 frame
WM06-03	Wall mounted

LCD Monitor, Keyboard and Mouse Support



Designed to hold a computer monitor, keyboard and mouse;
Usable surface of the keyboard and mouse tray: 23⁵/₈" W x 8¹/₂" D;
Includes one double articulating arm for the tray and one articulating arm for the screen;
Positioning of monitor anchors comply with VESA 75 and 100 standards;
Can support most LCD monitors up to 21" available on the market;
Tray and screen can also be tilted for better ergonomics;
Color: black;
Wall anchoring kit not included.

Product #	Model
WM05-22	For WM11 frame
WM06-22	Wall mounted

Laptop Support



Designed to hold a laptop computer, papers, binders or any other object;
Usable tray surface : 14" W x 12" D;
Includes one double articulating arm and the tray;
The double articulating arm allows for increased adjustability;
The tray can also be tilted for better ergonomics;
Color: black;
Wall anchoring kit not included.

Product #	Model
WM05-42	For WM11 frame
WM06-42	Wall mounted

LCD Monitor, Keyboard and Mouse Support



Designed to hold a computer monitor, keyboard and mouse;
Usable surface of the keyboard and mouse tray: 23⁵/₈" W x 8¹/₂" D;
Includes one articulating arm, the tray and adaptor for the screen;
Positioning of monitor anchors comply with VESA 75 and 100 standards;
Can support most LCD monitors up to 21" available on the market;
Tray and screen can also be tilted for better ergonomics;
Color: black;
Wall anchoring kit not included.

Product #	Model
WM06-21	Wall mounted

Electronic Tablet Support



Designed to support most electronic tablets on the market;
Includes one double articulating arm and the tablet support;
Safely holds the tablet in place;
The holding clamps and back of the support are rubberized to help prevent scratches and damage to the device;
The double articulating arm allows for increased adjustability;
The support can also be tilted for better ergonomics;
Color: black;
Wall anchoring kit not included;
Size of compatible tablet:
– small: 7 ⁵/₈" to 10" wide
– large: 9 ⁷/₈" to 12 ¹/₄" wide.

Product #	Version
WM05-62-01	Small for WM11 frame
WM05-62-02	Large for WM11 frame
WM06-62-01	Small for wall-mounted support
WM06-62-02	Large for wall-mounted support