

LIBERTY® SERIES

PORTABLE CAPSTAN WINCH W/ INTEGRAL SWIVEL BASE



Quiet Performance at Any Angle

The Thern Liberty Series capstan winch delivers portable strength and performance. The swivel base helps you deliver it, securely, at almost any angle for stringing, tensioning, pulling, and lifting—especially with the optional hitch mount. Position your truck once, rotate the winch (15° increments) to align the load, and lock it down. Then, enjoy quiet operation for enhanced team communication and productivity. It's perfect for energy sector tasks in remote locations, including pole setting, stringing lines, maintaining wind turbines, and erecting cell towers.

1,000 lb Capacity (450 kg)

- Quiet Operation and Long Life
- Load-Aligning Swivel Base
- Extremely Portable
- Improved Safety vs. Competitive Products
- Increased Productivity
- Maintenance-Free
- Two-Year Warranty

Premium Motor with Handle

- Premium motor offers quiet operation (80 dBA)* enhancing clear communication between operators
- Totally enclosed housing with durable powder-coat finish resists contamination for increased reliability
- Maintenance-free, permanently lubricated, planetary gearbox for smooth operation and long life
- UL-Recognized motor

*Thern's 3CP1S-AFS winch has a maximum noise level of 80 dBA, averaging 10 dBA less than the competition when measured at a distance of approximately three feet under similar conditions.

Engineered Drum Design

- Keeps load line from moving during operation, enhancing productivity
- Nickel-plated steel construction for optimum performance and durability

Durable Swivel Frame with Integral Lock

- Adjustable rotation in 15° increments to align loads and lock securely with swivel stop
- Lightweight, engineered design and steel construction enhance portability
- Powder-coated steel finish resists wear and promotes durability
- Half-inch, Grade 5 mounting hardware enhances security
- Optional heavy-duty fixed mount frame

Foot Switch Control

(not shown)

- Foot switch-controlled operation enhances productivity and safety
- IP65, NEMA 4-rated sealed foot switch allows outdoor use
- Painted, cast-iron construction and anti-skid feet promote durability and stability for outdoor applications
- 10-foot cord and twist-lock plug design aid convenience and prevent power disruption for enhanced productivity



PERFORMANCE

Series	IMPERIAL								
	Maximum Capacity	Rope Diameter Range**	Maximum Line Speed Range****	Rated Current Draw	Input Voltage	Ship Weight	Ambient Operating Temp. Range	Duty Cycle	Mount Type
3CP1S-AFS	1,000 lbs	½–¾ in	35–50 fpm	15 amp	115V/1 Phase /50-60Hz	76 lbs	-4 °F–+105 °F	20 mins full load	Swivel
3CP1M-AFS	1,000 lbs	½–¾ in	35–50 fpm	15 amp	115V/1 Phase /50-60Hz	64 lbs	-4 °F–+105 °F	20 mins full load	Fixed

Series	METRIC								
	Maximum Capacity	Rope Diameter Range**	Maximum Line Speed Range****	Rated Current Draw	Input Voltage	Ship Weight	Ambient Operating Temp. Range	Duty Cycle	Mount Type
3CP1S-AFS	450 kg	13–19 mm	11–15 mpm	15 amp	115V/1 Phase 50-60Hz	34 kg	-20°C–+40°C	20 mins full load	Swivel
3CP1M-AFS	450 kg	13–19 mm	11–15 mpm	15 amp	115V/1 Phase 50-60Hz	29 kg	-20°C–+40°C	20 mins full load	Fixed

Synthetic rope only. Available for purchase through Thern. *Load dependent.

Integral Rope Keep

- Spring-loaded rope keep helps prevent accidental removal of hand line from drum to enhance safety
- Corrosion-resistant components enhance durability
- Rope keep bar serves as a carrying handle

Integral Rope Lock

- Rope lock prevents unintentional drops to enhance safety
- Accommodates ½–¾ inch rope for varying loads
- Nickel-plated and anodized components enhance durability
- Adjustable rope lock accommodates various line exit angles and operator heights

Accessories

3CP1S-HM Hitch Mount**

- Heavy-duty (ASTM-grade steel) construction for 1,000-pound swivel capstan winch
- For use on vehicles with a 2-inch hitch receiver
- Hitch includes standard receiver clevis and cotter pins
- Red powder-coat finish
- Product weight is approximately 26 pounds for easy handling

**For use with Thern swivel capstan winch only.

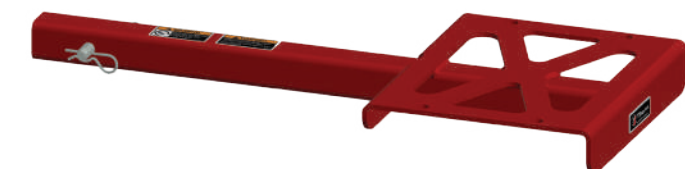

NOTICE: These products are not for lifting people or things over people.

CSCS-0820

DIMENSIONAL DRAWINGS



3CP1S-AFS

Plan View

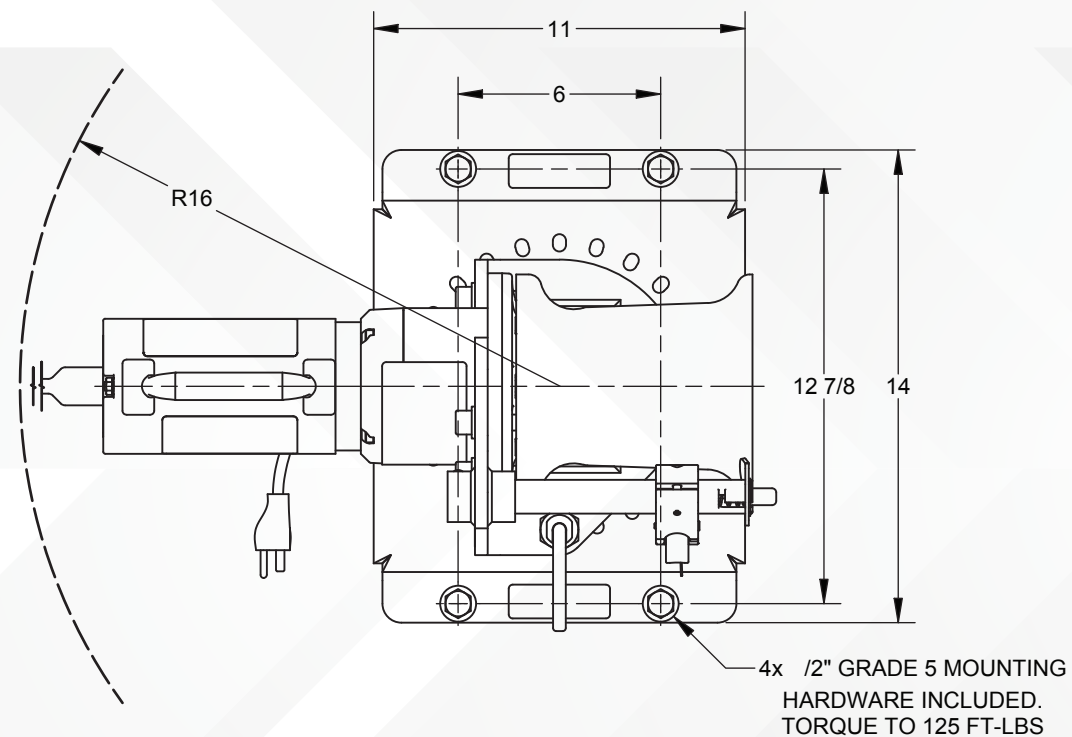

3CP1M-AFS

Top View

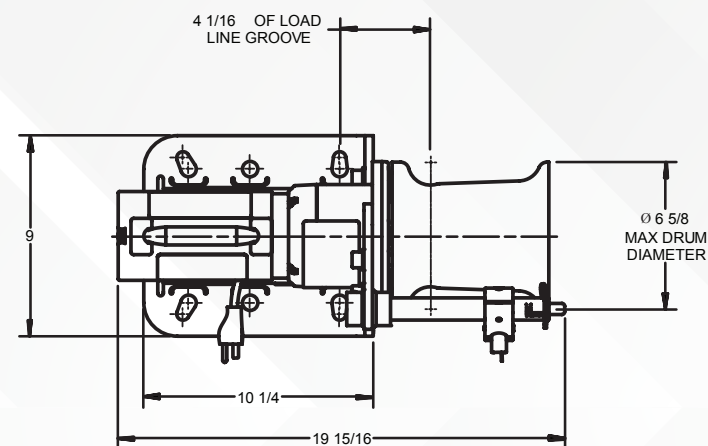

Mounting Pattern

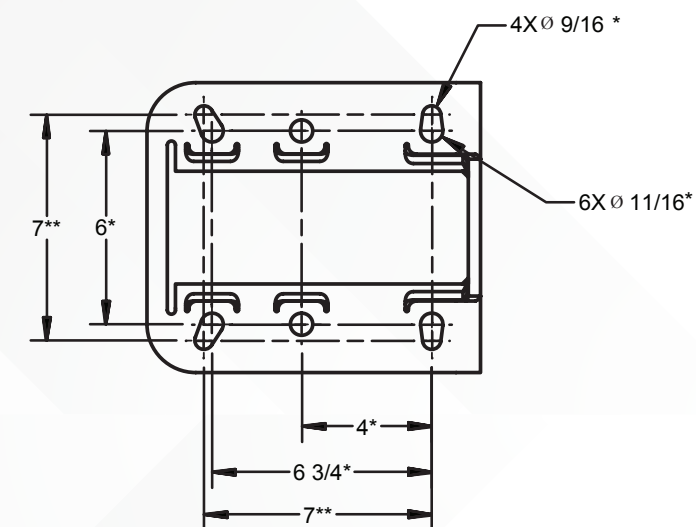

3CP1S-HM

Accessory

Hitch Mount Top View

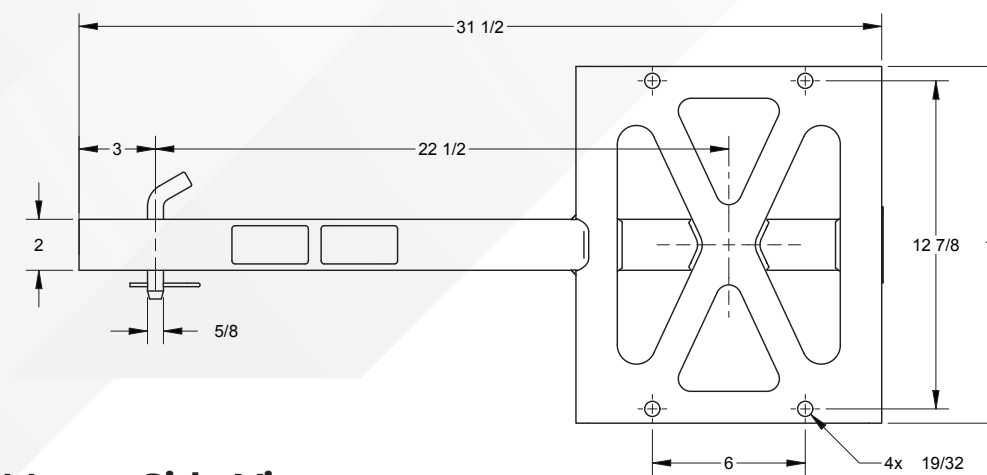

Hitch Mount Side View

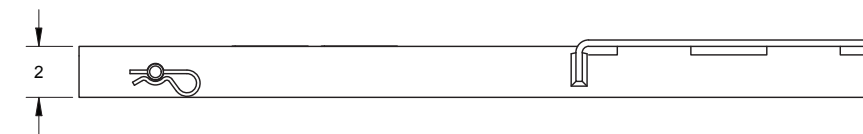

Front View

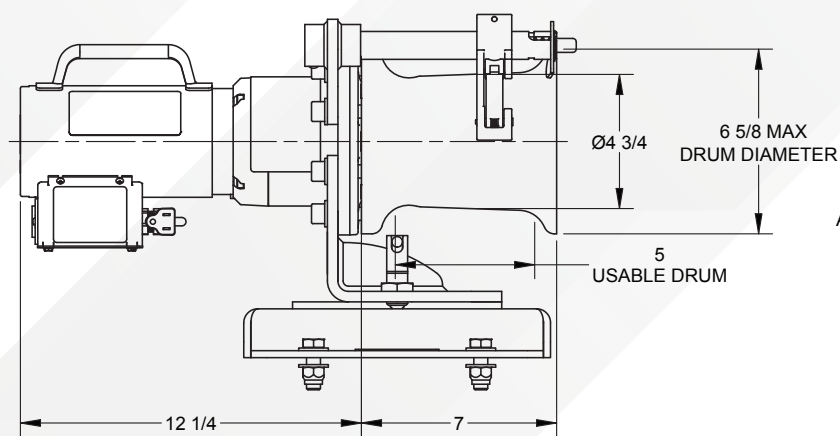

Right Side View

