



PORTABLE DAVIT CRANE

FIRST MATE® SERIES



FIRST MATE® 5PF5

PORTABLE DAVIT CRANE



ECONOMICAL, LIGHTWEIGHT & Easy-to-Use Lifting Power

The 5PF5 First Mate 500 portable davit crane (up to 850 pounds) isn't complicated—but it gets the job done with features and quality you expect from Thern. A fixed boom length, with three operating angles, makes it lightweight, easy to carry, and easy to use. It is perfect for simple jobs where adjustable length is not required. An ergonomic design makes it ideal for water/wastewater applications.



Product Shown:
5PF5-E2

STANDARD CONFIGURATIONS

Series	IMPERIAL/METRIC	
	Description	Up To Capacity
5PF5-M1	Powder-coat crane with M4022PB-K spur gear hand winch	850 lbs / 385 kg
5PF5G-M1	Galvanized crane with M4022PB-K spur gear hand winch	850 lbs / 385 kg
5PF5-M2	Powder-coat crane with 4WM2-K worm gear hand winch	850 lbs / 385 kg
5PF5G-M2	Galvanized crane with 4WM2-K worm gear hand winch	850 lbs / 385 kg
5PF5S-M3	Stainless-steel crane with M4042PBSS-K spur gear hand winch	850 lbs / 385 kg
5PF5-E2	Powder-coat crane with 4WP2-K electric winch	850 lbs / 385 kg

Enhanced Portability

- Disassemble and reassemble easily, using quick-release hardware and pins for quick transport or storage—no tools required
- Move your crane to another location while keeping the wire rope attached to the load using the quick-disconnect feature. Insert the swaged-ball end of the wire rope into the keyhole slot on the tab of the pedestal base or into an optional wire rope keeper or cable spool

Durable Construction & Finish

- Heavy-duty, welded structural steel pipe and tubing limit deflection and meet/exceed ASTM standards
- Corrosion-resistant, powder-coated frame, mast cap, and stainless-steel fasteners resist the elements for long service life
- Galvanized, epoxy, and 304 or 316 stainless-steel finishes are available for corrosive environments

Flexible Configurations

- A variety of base and mounting options, including pedestal, flush, and wall-mount, as well as wheel-base, help meet a variety of lifting needs
- A quick-mount winch bracket is standard (no tools required) and accommodates several Thern winches
- Optional base extension provides additional height without affecting the crane's load rating. Ideal for wall- or flush-mount situations to create additional crane height for obstacle clearance or other needs when 15 inches (381 mm) of additional height is required

360° Rotation & Flexible Operation

- Nylatron® bushing at base enhances smooth, 360-degree rotation under load for precise load placement. Optional rotation lock maintains load position for easier unloading
- Choose from manual, drill-drive, or powered winch (electric, pneumatic, or hydraulic motors) operation to accommodate a variety of light or heavy loads and travel distances. DC motors and various voltage AC motors available

NOTICE: These products are not for lifting people or things over people.

Refer to technical pages for detailed performance information.

FIRST MATE® PORTABLE DAVIT CRANE

CONFIGURATIONS

Model	Description	Approx. Ship Wt.	
		(lb)	(kg)
Popular Configurations			
5PF5-M1	up to 850 lb capacity with M4022PB-K spur gear hand winch—powder-coat crane	76	34
5PF5G-M1	up to 850 lb capacity with M4022PB-K spur gear hand winch—galvanized crane	76	34
5PF5-M2	up to 850 lb capacity with 4WM2-K worm gear hand winch—powder-coat crane	101	46
5PF5G-M2	up to 850 lb capacity with 4WM2-K worm gear hand winch—galvanized crane	101	46
5PF5S-M3	up to 850 lb capacity with M4042PBSS-K spur gear hand winch—stainless-steel crane	83	38
5PF5-E2	up to 850 lb capacity with 4WP2-K electric winch—powder-coat crane	144	65
Crane Only			
5PF5	up to 850 lb capacity—base model—powder-coat finish	59	27
5PF5G	up to 850 lb capacity—base model—galvanized finish	59	27
5PF5S	up to 850 lb capacity—base model—304 stainless-steel finish	59	27
5PF5S316	up to 850 lb capacity—base model—316 stainless-steel finish	59	27
5PF5X	up to 850 lb capacity—base model—epoxy-gray finish	59	27
Winch Only			
M1	M4022PB-K—spur gear hand winch only—zinc plated	17	8
M2	4WM2-K—worm gear hand winch only—powder coat	42	19
M2X	4WM2EGRA-K—worm gear hand winch only—epoxy gray	42	19
M3	M4042PBSS-K—spur gear hand winch only—stainless steel	24	11
E2	4WP2-K electric winch—115/1/60 VAC with 6 ft pendant control—enamel	85	39
E2X	4WP2EGRA-K electric winch—115/1/60 VAC with 6 ft pendant control—epoxy gray	85	39
E4	4777-K electric winch—115/1/60 VAC with 6 ft pendant control—enamel	110	50
E4X	4777EGRA-K electric winch—115/1/60 VAC with 6 ft pendant control—epoxy gray	110	50
E4DC	4777DC-K electric winch—12 volt DC with 10 ft pendant control—enamel	105	48
E4DCX	4777DCEGRA-K electric winch—12 volt DC with 10 ft pendant control—epoxy gray	105	48

Independent Bases—sold separately

Pedestal, socket (flush-mount), or wall-mount style.

Wheel base for floor crane operation. Base includes stationary front wheels and rear caster wheels for 360° maneuverability. See Model 5BR5.

IMPORTANT: Base installation is the purchaser's responsibility. Thern recommends consulting a civil engineer or other qualified professional. Contact Thern for installation guidelines.

Finishes	MODELS				
	Pedestal	Flush	Wall	Wheel	Extension
Powder Coat Paint	5BP5	5BF5	5BW5	5BR5	5BE5-15
Galvanized	5BP5G	5BF5G	5BW5G	—	5BE5-15G
304 Stainless Steel	5BP5S	5BF5S	5BW5S	—	5BE5-15S
316 Stainless Steel	5BP5S316	5BF5S316	5BW5S316	—	5BE5-15S316
Epoxy Paint	5BP5X	5BF5X	5BW5X	5BR5X	5BE5-15X
Approximate Ship Weight	21 lbs (9.5 kg)	21 lbs (9.5 kg)	23 lbs (10.4 kg)	77 lbs (35 kg)	17 lbs (7.7 kg)



Wire Rope Assemblies—sold separately

Galvanized or stainless steel wire rope assemblies with swaged-ball fitting to work with the quick-disconnect anchor on the winch. See wire rope page for stainless steel and additional wire rope options.

Wire Rope Length	Galvanized Aircraft Cable		304 Stainless Steel Wire Rope	
	3/16" Dia. (4.8 mm)	1/4" Dia. (6.4 mm)	3/16" Dia. (4.8 mm)	1/4" Dia. (6.4 mm)
(ft) (m)	Model No.	Model No.	Model No.	Model No.
20 6.0	WA19-20NS	WA25-20NS	WS19-20NS	WS25-20NS
28 8.5	WA19-28NS	WA25-28NS	WS19-28NS	WS25-28NS
36 10.9	WA19-36NS	WA25-36NS	WS19-36NS	WS25-36NS
45 13.7	WA19-45NS	WA25-45NS	WS19-45NS	WS25-45NS
60 18.2	WA19-60NS	WA25-60NS	WS19-60NS	WS25-60NS
75 22.8	WA19-75NS	WA25-75NS	WS19-75NS	WS25-75NS
90 27.4	WA19-90NS	—	WS19-90NS	—

PERFORMANCE

First Mate 5PF5 Series Performance¹ Lift Below Floor Level with Pedestal Base

Lift Below Floor ²	Wire Rope Diameter		Wire Rope Length		Winch Configurations Maximum Winch Rating												
	Minimum (C)	Maximum (A)	(in)	(mm)	(ft)	(m)	M1		M2		M3		E2		E4		
6	1.8	9	2.7	3/16"	5	20	6.0	850	385	—	—	850	385	—	—	850	385
14	4.2	17	5.1	3/16"	5	28	8.5	750	340	—	—	850	385	—	—	850	385
22	6.7	25	7.6	3/16"	5	36	10.9	660	299	—	—	850	385	—	—	850	385
31	9.4	34	10.3	3/16"	5	45	13.7	600	272	—	—	810	367	—	—	850	385
46	14.0	49	14.9	3/16"	5	60	18.2	—	—	—	—	740	335	—	—	850	385
61	18.5	64	19.5	3/16"	5	75	22.8	—	—	—	—	690	312	—	—	850	385
76	23.1	79	24.0	3/16"	5	90	27.4	—	—	—	—	640	290	—	—	850	385
106	32.3	109	33.2	3/16"	5	120	36.5	—	—	—	—	—	—	—	—	850	385
6	1.8	9	2.7	1/4"	6	20	6.0	—	—	850	385	850	385	850	385	850	385
14	4.2	17	5.1	1/4"	6	28	8.5	—	—	850	385	830	376	850	385	850	385
22	6.7	25	7.6	1/4"	6	36	10.9	—	—	850	385	740	335	850	385	850	385
31	9.4	34	10.3	1/4"	6	45	13.7	—	—	850	385	740	335	850	385	850	385
46	14.0	49	14.9	1/4"	6	60	18.2	—	—	850	385	—	—	850	385	850	385
61	18.5	64	19.5	1/4"	6	75	22.8	—	—	850	385	—	—	850	385	850	385
76	23.1	79	24.0	1/4"	6	90	27.4	—	—	—	—	—	—	—	—	—	—
106	32.3	109	33.2	1/4"	6	120	36.5	—	—	—	—	—	—	—	—	—	—

For longer lifts, please contact factory.

¹ Performance characteristics are for standard products. Non-standard products may vary from the original design. Contact Thern, Inc. for this information.

² Lift below floor level varies depending on boom position and base configuration. For longer lifts, please contact factory.

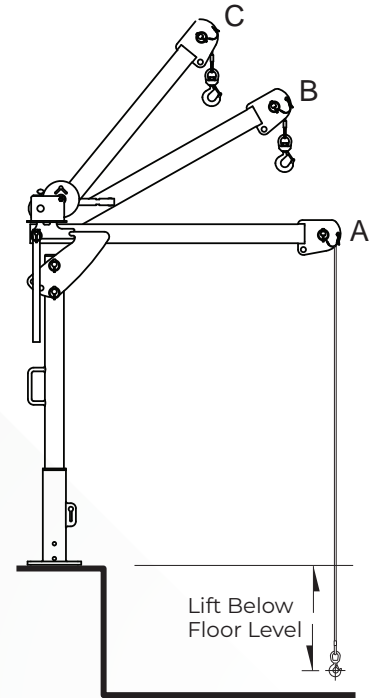

Winch Configurations



First Mate Performance Ratings with Pedestal Base¹

Boom Position	Load Rating		Hook Reach		Hook Height	
	(lb)	(kg)	(in)	(mm)	(in)	(mm)
A	500	226	42	1,066	40	1,016
B	600	272	35	889	60	1,524
C	850	385	24	609	70	1,778

¹ Performance characteristics are for standard products. Non-standard products may vary from the original design. Contact Thern, Inc. for this information.
Dimensions are for reference only and subject to change without notice.

First Mate Pedestal Base

5BP5 5BP5S 5BP5X
5BP5G 5BP5S316

Pedestal Base

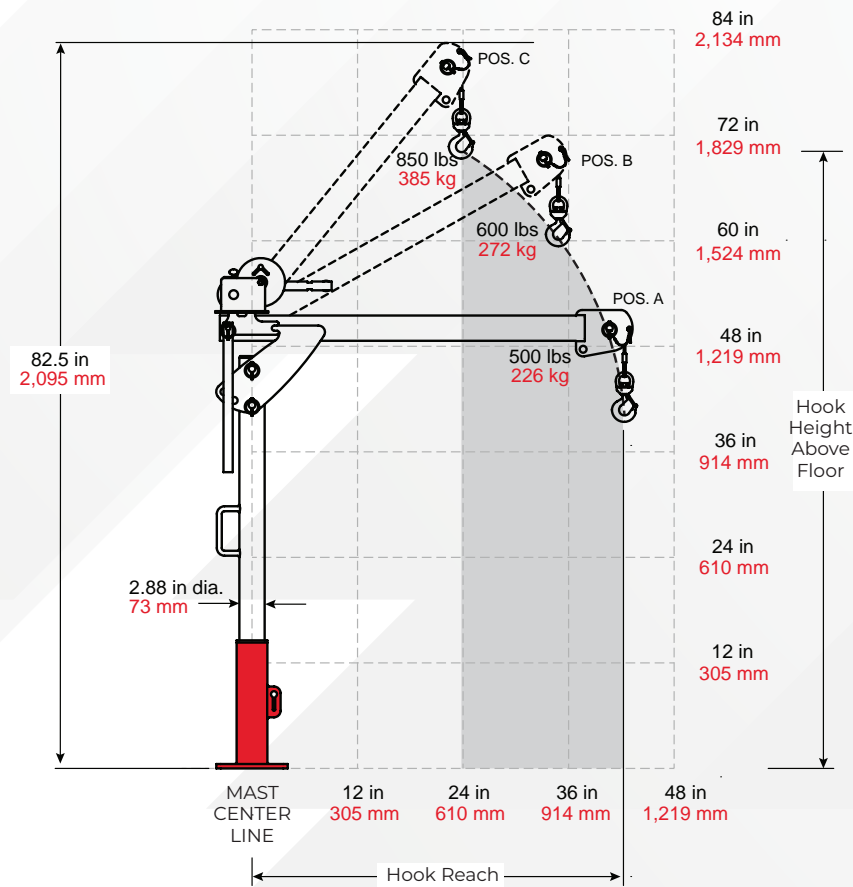
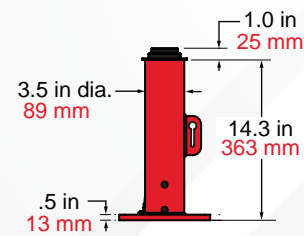
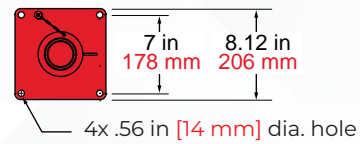

First Mate Performance Ratings with Flush- or Wall-Mount Bases¹

Boom Position	Load Rating		Hook Reach		Hook Height	
	(lb)	(kg)	(in)	(mm)	(in)	(mm)
A	500	226	42	1,066	26	660
B	600	272	35	889	46	1,168
C	850	385	24	609	56	1,422

¹ Performance characteristics are for standard products. Non-standard products may vary from the original design. Contact Thern, Inc. for this information.
Dimensions are for reference only and subject to change without notice.

First Mate Flush-Mount Base

5BF5 5BF5S 5BF5X
5BF5G 5BF5S316

Flush- or Wall-Mount Base

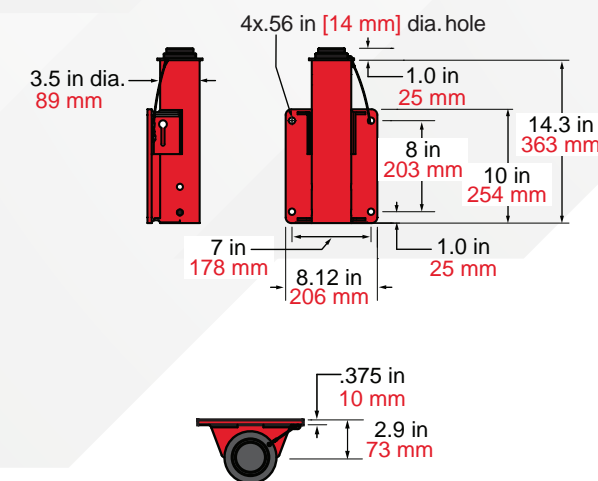
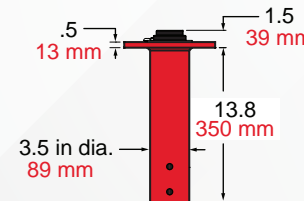
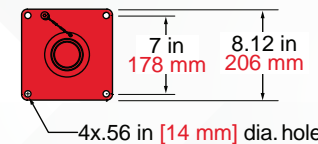

First Mate Wall-Mount Base

5BW5 5BW5S 5BW5X
5BW5G 5BW5S316

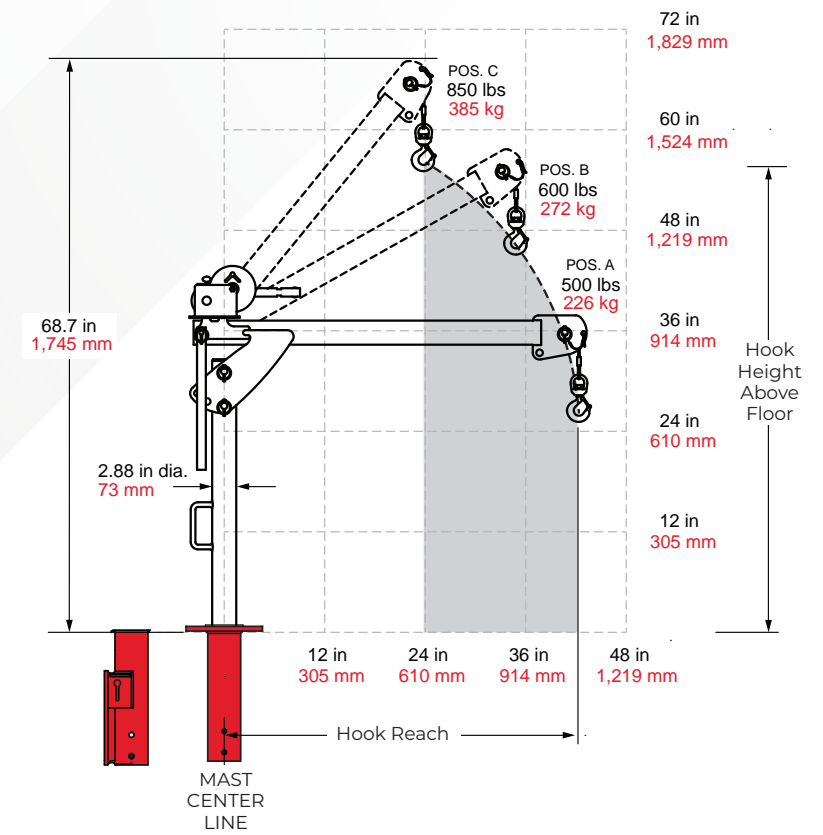

First Mate Performance Ratings with Wheel Base¹

Boom Position	Load Rating		Hook Reach		Hook Height	
	(lb)	(kg)	(in)	(mm)	(in)	(mm)
A	500	226	42	1,066	44.5	1,130
B	600	272	35	1,524	64.5	1,638
C	850	385	24	1,778	74.5	1,892

¹ Performance characteristics are for standard products. Non-standard products may vary from the original design. Contact Thern, Inc. for this information.

Dimensions are for reference only and subject to change without notice.

First Mate Wheel Base

5BR5

5BR5X

Wheel Base

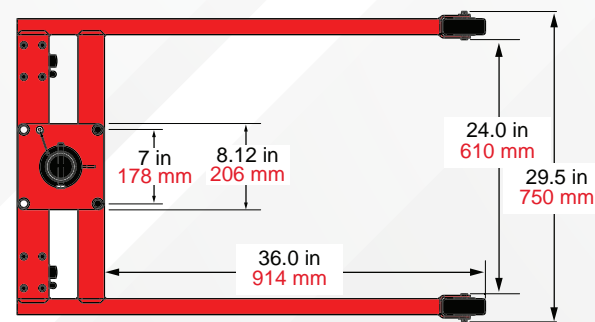
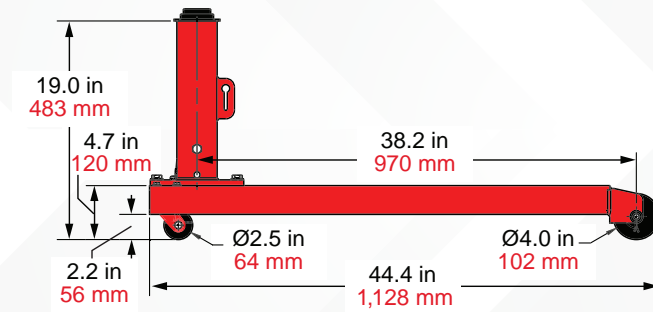

IMPORTANT:
Crane DOES NOT rotate when assembled in 5BR wheel base.

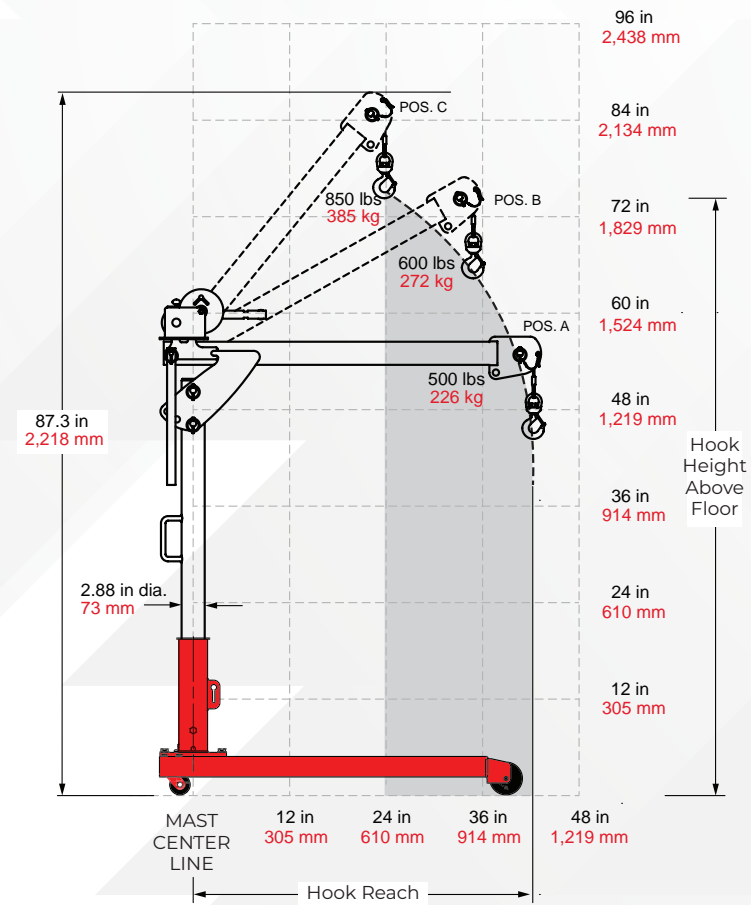

CRANE

OPTIONS & ACCESSORIES



Base Anchor Kit

Model	Description
AN50A-5	(4) Hilti® zinc-plated steel fasteners 1/2" X 5.50" STL (5PA5, 5PF5, and 5PT5 cranes)
AN50A-5S	(4) Hilti® 304 stainless-steel fasteners 1/2" X 5.50" SST304 (5PA5, 5PF5, and 5PT5 cranes)
AN50A-5S316	(4) Hilti® 316 stainless-steel fasteners 1/2" X 5.50" SST316 (5PA5, 5PF5, and 5PT5 cranes)
AN62A-6	(4) Hilti® zinc-plated steel fasteners 5/8" X 6.00" STL (5PA10, 5PT10, 5PT20, and 5FT20 cranes)
AN62A-6S	(4) Hilti® 304 stainless-steel fasteners 5/8" X 6.00" SST304 (5PA10, 5PT10, 5PT20, and 5FT20 cranes)
AN62A-6S316	(4) Hilti® 316 stainless-steel fasteners 5/8" X 6.00" SST316 (5PA10, 5PT10, 5PT20, and 5FT20 cranes)



Rotational Lock

Model	Description
5P5LCK	For pedestal, wall, and flush-mount bases, 316 stainless steel—available for use 5PA5, 5PF5, and 5PT5



Cable Spooler

Model	Description
RW50	316 stainless-steel reel winds up wire rope when detached from crane



Wire Rope Keeper

Model	Description
RK19-25S	304 Stainless-steel bracket holds free end of the wire rope when detached from the crane
RK19-25S316	316 Stainless-steel bracket holds free end of the wire rope when detached from the crane



Roller Ball Bearing for 5PT10 Series Crane

Model	Description
5PT10BRG	Red electrostatic, powder-coat paint finish
5PT10BRG-S	304 stainless-steel, electro-polished finish for added protection against corrosion
5PT10BRG-S316	Stainless-steel, electro-polished finish for maximum protection against corrosion
5PT10BRG-SS	304 stainless steel, for use with stainless-steel base only
5PT10BRG-SS316	316 stainless steel, for use with stainless-steel base only



Roller Ball Bearing for 5PT20 Series Crane

Model	Description
5PT20BRG	Red electrostatic, powder-coat paint finish
5PT20BRG-S	304 stainless-steel, electro-polished finish for added protection against corrosion
5PT20BRG-S316	Stainless-steel, electro-polished finish for maximum protection against corrosion
5PT20BRG-SS	304 stainless steel, for use with stainless-steel base only
5PT20BRG-SS316	316 stainless steel, for use with stainless-steel base only



Limit Switch Ready Winch Options

Model	Description
NOTE: Limit switch winch option requires purchase of Limit Switch and Headache Ball (sold separately)	
For 5PF5, 5PA5, 5PA10, 5PT5, 5PT10, 5PT20 Series Cranes (sold separately)	
E2L (5PA5, 5PA10)	4WP2V-KL electric winch – 115/1/60 VAC with 6 ft pendant control – enamel
E2LX (5PA5, 5PA10)	4WP2VEGRA-KL electric winch – 115/1/60 VAC with 6 ft pendant control – epoxy gray
E4L	4777-KL electric winch – 115/1/60 VAC with 6 ft pendant control – enamel
E4LX	4777EGRA-KL electric winch – 115/1/60 VAC with 6 ft pendant control – epoxy gray
E4DCL	4777DC-KL electric winch – 12 volt DC with 10 ft pendant control – enamel
E4DCLX	4777DCEGRA-KL electric winch – 12 volt DC with 10 ft pendant control – epoxy gray
For 5FT20 Series Crane Only (sold separately)	
E2L	4WP2-KL electric winch – 115/1/60 VAC with 6 ft pendant control – enamel
E2LX	4WP2EGRA-KL electric winch – 115/1/60 VAC with 6 ft pendant control – epoxy gray
E4L	4771-KL electric winch – 115/1/60 VAC with 6 ft pendant control – enamel finish
E4LX	4771EGRA-KL electric winch – 115/1/60 VAC with 6 ft pendant control – gray-epoxy finish
E4DCL	E4DCL 4771DC-KL electric winch – 12 volt DC with 10 ft pendant control – enamel finish
E4DCLX	4771DCEGRA-KL electric winch – 12 volt DC with 10 ft pendant control – gray-epoxy finish
For 5PT30, 5FT25, 5FT40 Series Crane Only (sold separately)	
E2L	3WG4B-KL electric winch - 115/1/160 VAC with 6 ft pendant control – enamel finish
E2LX	3WG4BEGRA-KL electric winch - 115/1/160 VAC with 6 ft pendant control – epoxy gray finish
E2TL	3WG4BMT-K electric winch - 115/1/160 VAC with 6 ft pendant control – enamel finish (Unavailable for use with 5FT40)
E2TLX	3WG4MTX-KL electric winch - 115/1/160 VAC with 6 ft pendant control – epoxy gray finish



Drill Drive Kit

Model	Description
ED330-DW11	120 VAC, 11-amp, 330 rpm drill motor to power drive the hand winch. Only available for cranes configured with the M2 winch option. Includes 1-1/8" hex drive socket
ED300-DW06	Cordless drill kit, 60 V brushless motor, 300 rpm drill motor to power drive the M2 hand winch option. Includes 1-1/8" hex drive socket
ED400-DW09	Heavy-duty cordless drill kit, 60 V brushless motor, 400 rpm drill motor to power drive the M2 hand winch option. Includes 1-1/8" hex drive socket



Headache Ball

Model	Description
HB10-12-25	Red enamel painted 10 lb fits 1/8" to 1/4" rope
HB10-25-38	Red enamel painted 10 lb fits 1/4" to 3/8" rope
HB10S-12-25	Stainless-steel 10 lb fits 1/8" to 1/4" rope
HB10S-25-38	Stainless-steel 10 lb fits 1/4" to 3/8" rope
HB10S-44-50	Stainless-steel 10 lb fits 7/16" to 1/2" rope



Base Extension

Model	Description
5BE5-15	Available on 5PF5, 5PT5, 5PT10, and 5PT20 with powder-coat, galvanized, 304 & 316 stainless-steel, and epoxy finishes
5BE10-15	
5BE20-15	