

# FIXED STEEL LADDERS

## SIDE-STEP AND WALK-THRU WELDED STEEL DOCK LADDERS

SEE PAGE 4

**NEW!**  
**MODULAR SERIES M**  
 • Easier to Install  
 • Reduces Freight Damage



### NOW

- FOUR MANUFACTURING LOCATIONS TO SERVE YOU CALIFORNIA, MICHIGAN, GEORGIA AND TEXAS

(eastern standard time)



**Cotterman Co.**  
 Division of Material Control, Inc.

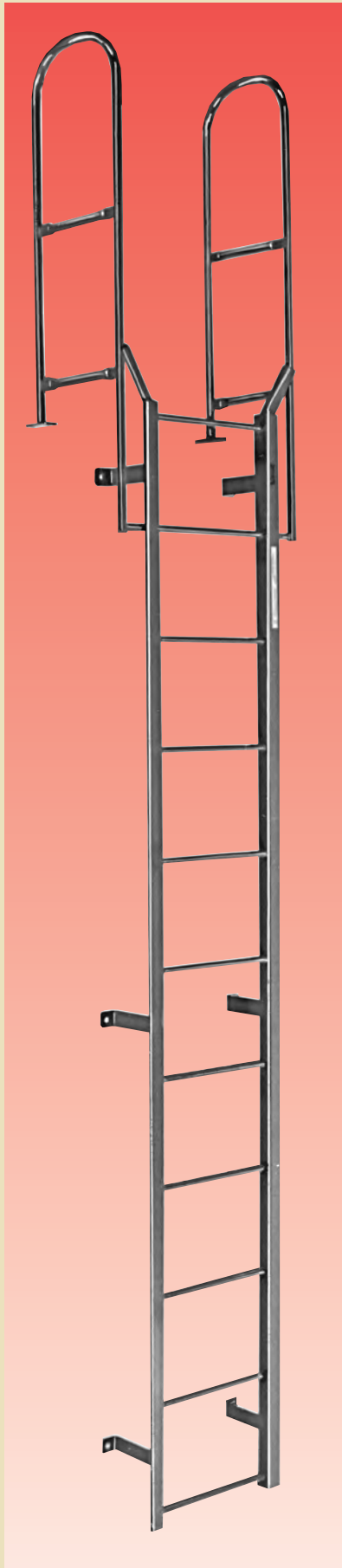

# FIXED STEEL LADDERS – SERIES F AND SERIES M



Cotterman fixed steel ladders are designed for use where safe, solid vertical climbing access is required. Series F and Series M modular fixed steel ladders are available with and without walk-thru handrails at the top landing surface. Standard fixed and walk-thru models can be used up to 20' without safety cages. OSHA requires safety cages on ladder heights exceeding 20'. Separate cages are offered for updating older ladders to current safety standards. All Cotterman fixed ladders meet or exceed OSHA 1910.27 and 1926.1053 standards.

**SERIES F FIXED LADDERS:** Ladders are heavy duty one-piece welded assemblies.

**SERIES M MODULAR FIXED LADDERS:** Ladders are heavy duty sub-assemblies, no section is greater than 7' in length.

**CONSTRUCTION FEATURES:**

- Side members are 1/4"x2"x2" steel angle. Climbing rungs are 3/4" corrugated steel round rungs space on 12" centers. Stand-off brackets are 7".
- Gray powder coat finish is standard color, yellow available.

**FIXED LADDERS WITH SAFETY CAGES:**

Standard fixed steel ladders are combined with safety cage protection. They are available in 10' through 29' sizes and are ideal for hatch-way or side step landing access.

**CAGE FEATURES:**

- OSHA design safety cages have flared bottom opening for easy entry.
- Left or right side step access cage designs are available at no charge.
- Cage begins 7' from bottom of ladder.
- Gray powder coat finish, yellow available.

**FIXED LADDER WITH WALK-THRU HANDRAILS:**

Ladders are designed for applications where safe landing access is required. They are one-piece welded assemblies for use in applications less than 20' in vertical height.

**CONSTRUCTION FEATURES:**

- Side members are 1/4"x2"x2" steel angle. 3/4" corrugated steel round climbing rungs on 12" centers. Stand-off mounting brackets are 7".
- Walk-thru handrails extend 42" above landing surface. Mounting brackets included.
- Welded one-piece, gray powder coat finish, yellow available.

**FIXED LADDER WITH WALK-THRU HANDRAILS AND SAFETY CAGES:**

Designed for safe landing access and available from 10' to 29'. Cages and walk-thru handrails extend 42" above landing surface.

**CAGE FEATURES:**

- Safety cages are designed to OSHA specifications with flared bottom opening for easy entry.
- Cage begins 7' from bottom of ladder.
- Gray powder coat finish, yellow available.



14 RUNG STANDARD F14S



14 RUNG WITH CAGE F14SC



11 RUNG WITH WALK-THRU F11W



11 RUNG WITH WALK-THRU AND CAGE: F11WC

SPECIFICATIONS			STANDARD			WITH CAGE						
OVERALL LENGTH	LENGTH: TOP TO BOTTOM RUNG	NO. RUNGS	SERIES "F" MODEL NO.	SHPG. WT.	PRICE	SERIES "M" MODEL NO.	SERIES "F" MODEL NO.	SHPG. WT.	PRICE			
3'3"	3'	4	F4S	35		<b>OSHA NOTE:</b> Although not required by OSHA, safety caging is offered on 11 thru 20 rung models.						
4'3"	4'	5	F5S	43								
5'3"	5'	6	F6S	52								
6'3"	6'	7	F7S	60								
7'3"	7'	8	F8S	68								
8'8"	8'	9	F9S	77								
9'3"	9'	10	F10S	88								
10'3"	10'	11	F11S	96	M11SC					F11SC	156	
11'3"	11'	12	F12S	105	M12SC					F12SC	182	
12'3"	12'	13	F13S	113	M13SC					F13SC	197	
13'3"	13'	14	F14S	122	M14SC	F14SC	213					
14'3"	14'	15	F15S	130	M15SC	F15SC	268					
15'3"	15'	16	F16S	139	M16SC	F16SC	282					
16'3"	16'	17	F17S	150	M17SC	F17SC	298					
17'3"	17'	18	F18S	158	M18SC	F18SC	316					
18'3"	18'	19	F19S	167	M19SC	F19SC	342					
19'3"	19'	20	F20S	175	M20SC	F20SC	357					
20'3"	20'	21	-	-	M21SC	F21SC	373					
21'3"	21'	22	<b>OSHA NOTE:</b> Fixed ladder heights exceeding 20' are required to have safety caging.			M22SC	F22SC	388				
22'3"	22'	23				M23SC	F23SC	414				
23'3"	23'	24				M24SC	F24SC	429				
24'3"	24'	25				M25SC	F25SC	444				
25'3"	25'	26				M26SC	F26SC	471				
26'3"	26'	27				M27SC	F27SC	486				
27'3"	27'	28				M28SC	F28SC	501				
28'3"	28'	29				M29SC	F29SC	559				
29'3"	29'	30				M30SC	F30SC	575				

**OSHA NOTE:** Heights exceeding 30' require a standoff platform (see option model SP)  
**SHIPPING NOTE:** All 15 thru 28 rung Series F models with cages ship in 2 sections. All 29 and 30 rung models ship in 3 sections.  
**HOT DIP GALVANIZED FINISH OR STAINLESS STEEL CONSTRUCTION CAN BE QUOTED.**

SPECIFICATIONS			WALK-THRU RAIL			WITH WALK THRU & CAGE							
OVERALL LENGTH	LENGTH: TOP TO BOTTOM RUNG	NO. RUNGS	SERIES "F" MODEL NO.	SHPG. WT.	PRICE	SERIES "M" MODEL NO.	SERIES "F" MODEL NO.	SHPG. WT.	PRICE				
6'8"	3'	4	F4W	61		<b>OSHA NOTE:</b> Although not required by OSHA, safety caging is offered on 8 thru 20 rung models.							
7'8"	4'	5	F5W	70									
8'8"	5'	6	F6W	78									
9'8"	6'	7	F7W	87									
10'8"	7'	8	F8W	95						F8WC	167		
11'8"	8'	9	F9W	104						F9WC	194		
12'8"	9'	10	F10W	115						F10WC	211		
13'8"	10'	11	F11W	123						M11WC	F11WC	226	
14'8"	11'	12	F12W	132						M12WC	F12WC	242	
15'8"	12'	13	F13W	140						M13WC	F13WC	268	
16'8"	13'	14	F14W	148		M14WC	F14WC	284					
17'8"	14'	15	F15W	157		M15WC	F15WC	327					
18'8"	15'	16	F16W	165		M16WC	F16WC	353					
19'8"	16'	17	F17W	176		M17WC	F17WC	369					
20'8"	17'	18	F18W	185		M18WC	F18WC	384					
21'8"	18'	19	F19W	193		M19WC	F19WC	401					
22'8"	19'	20	F20W	202		M20WC	F20WC	428					
23'8"	20'	21	-	-		M21WC	F21WC	443					
24'8"	21'	22	<b>OSHA NOTE:</b> Fixed ladder heights exceeding 20' are required to have safety caging.			M22WC	F22WC	458					
25'8"	22'	23				M23WC	F23WC	485					
26'8"	23'	24				M24WC	F24WC	500					
27'8"	24'	25				M25WC	F25WC	515					
28'8"	25'	26				M26WC	F26WC	571					
29'8"	26'	27				M27WC	F27WC	586					
30'8"	27'	28				M28WC	F28WC	601					
31'8"	28'	29				M29WC	F29WC	619					
32'8"	29'	30				M30WC	F30WC	634					

**OSHA NOTE:** Heights exceeding 30' require a standoff platform (see option model SP)  
**SHIPPING NOTE:** All 15 thru 25 rung Series F models with cages ship in 2 sections. All 26 thru 30 rung models ship in 3 sections.  
**HOT DIP GALVANIZED FINISH OR STAINLESS STEEL CONSTRUCTION CAN BE QUOTED.**

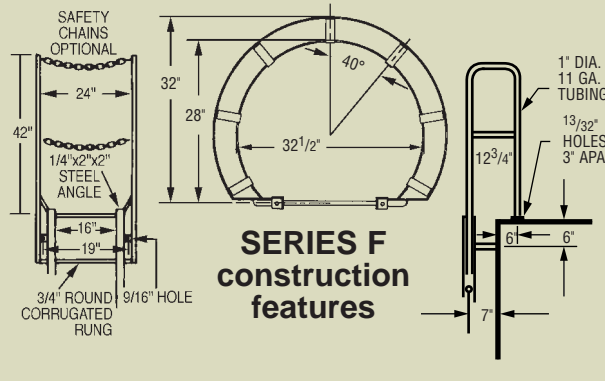
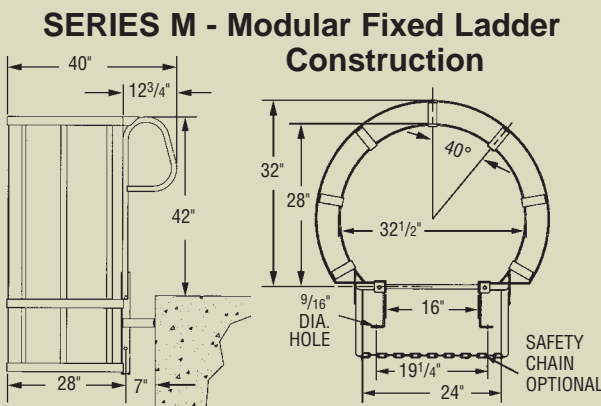

## ACCESSORIES

Cotterman fixed steel ladder accessories are designed to provide an additional measure of safety or security for any fixed steel ladder.

### SP STANDOFF LANDING PLATFORM

Standoff landing platforms with offset caged ladders are required by OSHA Standard 1910.27 at 30' maximum height intervals. These rugged, pre-engineered platforms are constructed with left or right entries as required.

**OPTION SP** ..... Shipping wt. 153 lbs.

A MINIMUM OF 11' DIA. SURFACE REQUIRED FOR MOUNTING

### CG SECURITY CAGE ENTRY GATE

The cage security gate is designed to prevent unauthorized entry into the bottom of the ladder cage. Doors have lockable hasp for complete security.

**OPTION CG** . . . Shipping wt. 31 lbs.

### LG SECURITY LADDER GUARD

The ladder guard is mounted directly over the ladder climbing rungs to prevent unauthorized use. It is available in either 6' or 8' lengths. The guard has a one piece piano hinge, and is furnished with lock-open and lock-closed hasps.

**OPTION LG-6** . . . Shipping wt. 130 lbs.  
**OPTION LG-8** . . . Shipping wt. 148 lbs.

### D3 SAFETY CHAIN ATTACHMENT

The safety chain attachment is used on the walk-thru handrails to prevent accidental exit from the top landing surface.

**OPTION D3** . . .

# Cotterman®



"CHARGE IT"

**COTTERMAN SERIES C WELDED STEEL CAGES** are one-piece welded assemblies designed for attachment to existing fixed ladders up to 20" wide. A wide range of standard lengths is offered with custom sizes available. To determine the proper length, the cage should begin 7' to 8' from the floor and extend 42" above the landing surface (except for hatchways).

**FEATURES:**

- Series C cages are designed in compliance with OSHA Standards 1910.27
- Standard cage lengths are available from 7'6" to 27'6".
- Cages are crated for shipping protection.
- Wider bottom flare openings are provided for easy entry.
- One-piece all welded steel with gray powder coat finish.
- Hot dip galvanized finish or stainless steel construction can be quoted.

## SERIES C WELDED STEEL CAGES

LENGTH	MODEL	SHPG.	PRICE
7'6"	C075	229	
8'6"	C085	255	
9'6"	C095	291	
10'6"	C105	316	
11'6"	C115	340	
12'6"	C125	365	
13'6"	C135	401	
14'6"	C145	426	
15'6"	C155	451	
16'6"	C165	476	
17'6"	C175	512	
18'6"	C185	536	
19'6"	C195	561	
20'6"	C205	586	
21'6"	C215	622	
22'6"	C225	646	
23'6"	C235	671	
24'6"	C245	696	
25'6"	C255	732	
26'6"	C265	756	
27'6"	C275	781	

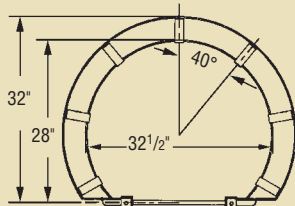

©COPYRIGHT COTTERMAN CO. 1986

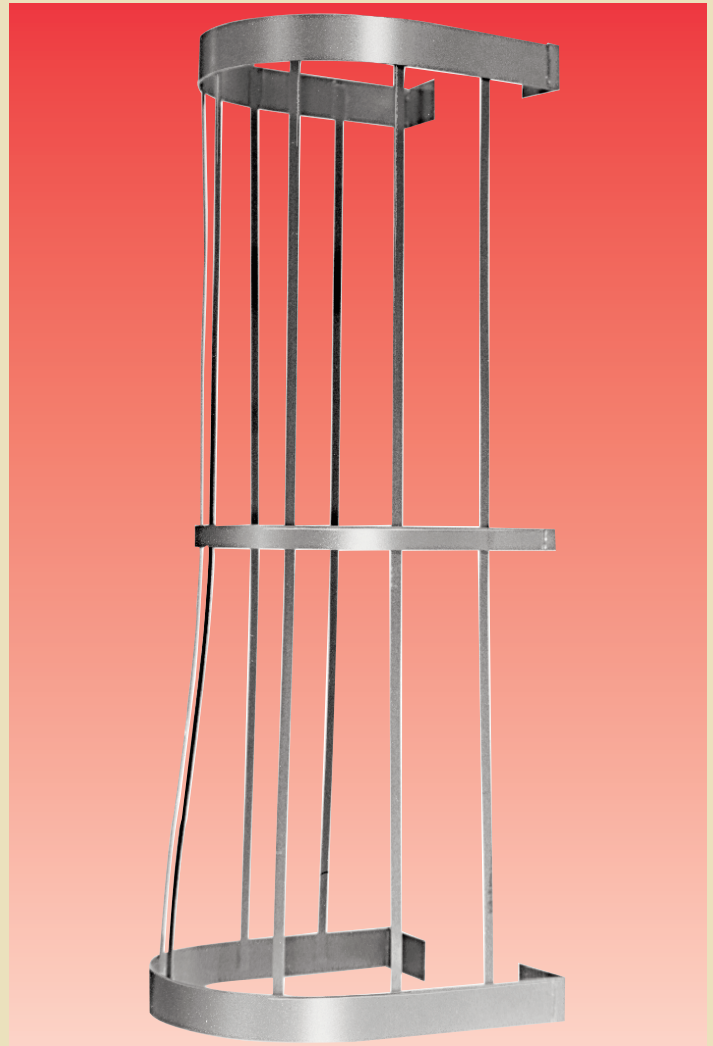

25/64" HOLES 3" APART

25/64" HOLES 3" APART

21 1/2"

SIDE-STEP 7 RUNG - D3SS

## WELDED STEEL DOCK LADDERS

One-piece welded assemblies that provide safe access to docks and mezzanines. Walk-thru models have 42" high handrails. Side step models have step rungs plus 4 additional hand rungs.

**FEATURES:**

- Constructed of 1 1/4" tube with 3/4" non-slip solid round rungs.
- 18" wide steps on side step models and 24" on walk-thru models, spaced on 12" centers.
- Walk-thru models have flat supports for easy mounting.
- Gray powder coat is standard finish.

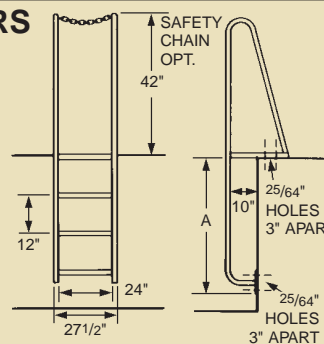

WALK-THRU 4 RUNG - D4WT

## SERIES D

NO. STEP RUNGS	TOTAL RUNGS	DIM. B	SHPG. WT.	MODEL NO.	PRICE
2	6	6'	33	D2SS	
3	7	7'	38	D3SS	
4	8	8'	42	D4SS	
5	9	9'	47	D5SS	
6	10	10'	51	D6SS	
7	11	11'	56	D7SS	
8	12	12'	61	D8SS	
9	13	13'	65	D9SS	
10	14	14'	70	D10SS	

NO. STEP RUNGS	DIM. A	SHPG. WT.	MODEL NO.	PRICE
2	1'6"	34	D2WT	
3	2'6"	39	D3WT	
4	3'6"	45	D4WT	
5	4'6"	50	D5WT	
6	5'6"	55	D6WT	
7	6'6"	61	D7WT	
8	7'6"	66	D8WT	
9	8'6"	71	D9WT	
10	9'6"	77	D10WT	