

Model 4771 shown with wire rope



Wire rope assemblies sold separately

Model 4771PN



Series 477 Helical/Worm Gear Power Winches Up to 2000 lb capacity

- **Machine Cut Gears** for accurate and long lasting service.
- **Enclosed Oil Bath** provides continuous lubrication of gears to minimize wear. Oil seals keep oil in and dirt out.
- **Internal Mechanical Brake** for positive load control.
- **Cast Aluminum** construction for lightweight strength, with durable paint finish to resist corrosion.
- **Ball Bearings** ensure smooth and efficient operation.
- **Series 4777** is designed with a 4 inch wide drum for tight fleet angle installations.
- **Accessory Options** include limit switches, cable pressure plates, torque limiting controls, and manual overrides.
- **Large Diameter Drums** minimize wear to the wire rope and help extend its life.
- **Mounting Options** include floor, wall, or ceiling.
- **Two-year Limited Warranty**

Series 477 – Configurations and Performance Characteristics – Section 2

model number	motor description	motor hp	load rating (lb)			wire rope dia. (in)	line speed (fpm)		drum capacity (ft) ¹			approx. ship wt. (lb)
			1st layer	mid drum	full drum		1st layer	full drum	1st layer	mid drum	full drum	
4771 ²	115/1/60 VAC – 6 ft pendant	1.2	2000	1500	1200	5/16	13	22	13	40	90	88
4771AC-1PH	115/1/60 VAC – less controls	1.2	2000	1500	1200	5/16	13	22	13	40	90	87
4771AC-1PH2 ³	115/230/1/60 VAC – less controls	1.5	2000	1500	1200	5/16	13	22	13	40	90	115
4771AC-3PH ³	230/460/3/60 VAC – less controls	1.5	2000	1500	1200	5/16	13	22	13	40	90	111
4771DC ⁴	12 VDC – with 10 ft pendant	1.0	2000	1500	1200	5/16	13	22	13	40	90	105
4771PN ^{4,5}	pneumatic – less controls	1.2	2000	1500	1200	5/16	13	22	13	40	90	70
4771HY ^{4,5}	hydraulic – less controls	2.3	2000	1500	1200	5/16	13	22	13	40	90	72
4777 ²	115/1/60 VAC – 6 ft pendant	1.2	2000	1500	1200	5/16	13	22	7	27	60	93
4777DC ⁴	12 VDC – with 10 ft pendant	1.0	2000	1500	1200	5/16	13	22	7	27	60	105

Please contact factory or nearest Them Distributor for firm fixed price and delivery.

¹ Actual drum capacities may be 25-30% less, due to nonuniform winding. Tension in wire rope will also affect drum capacity.

² Motor includes an 8 ft. power cord with grounded plug, and a push button pendant control on 6 ft cord.

³ For Models 4771AC-1PH2 and 4771AC-3PH, please specify voltage when ordering.

⁴ For pneumatic, hydraulic, and DC models, line speed is based on rated load, actual line speed varies with load weight and power supply.

⁵ For Model 4771PN, ratings are for 80 cfm at 100 psi. For Model 4771HY, ratings are for 4 gpm at 1000 psi.

Notes:

■ For more information and other control options, please see pages 46-47.

■ Custom controls are available including wireless remote control, variable speed control, electronic overload, and enclosures for special environments.

Series 477 – Controls – Section 2

model	description	approx. ship wt.
10L2A1 ⁶	NEMA 1 control switch – mounted and wired	3 lb
10L2A4 ⁶	NEMA 4 watertight control switch – mounted and wired	7 lb
477PN-CNTRL	pneumatic control valve (not mounted or plumbed, no hoses)	6 lb
477PN-HS6	6 ft hoses for pneumatic controls (not plumbed)	4 lb
477HY-CNTRL	hydraulic control valve (not mounted or plumbed, no hoses)	5 lb
477HY-HS6	6 ft hoses for hydraulic controls (not plumbed)	4 lb

Please contact factory or nearest Them Distributor for firm fixed price and delivery.

⁶ Controls for 115 volt, single phase, 60 cycle include an 8 ft. power cord with grounded plug.

See Dimensions on Next Page

Options and Accessories

- **Emergency Hand Crank** for manual operation in case of power failure. Does not include handle.
- **Rotary Limit Switches** for secondary shut-off to limit load travel in one or two directions.
- **Special Motors and Controls** including severe duty and explosion proof.
- **Special Finishes** for hazardous environments.
- **Torque Limiters** as part of the motor controls on electric models.

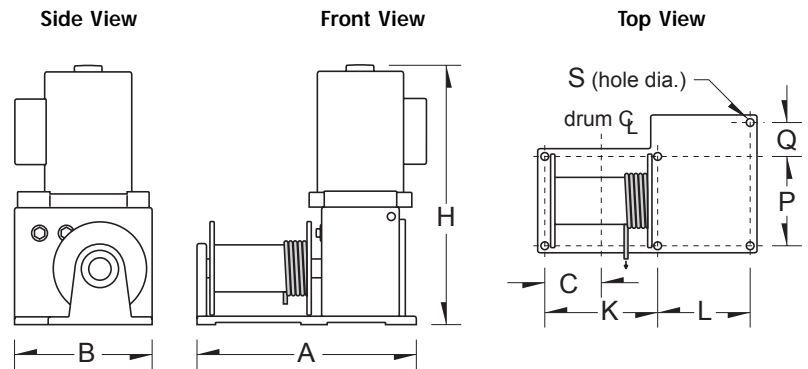

Install wire rope correctly as shown, or brake will not operate properly.

Series 477 – Winch Dimensions (in)

model number	A	B	C	H	K	L	P	Q	S (hole dia.)
4771	14.38	8.86	3.55	17.45	6.75	6.31	5.70	2.16	.34
4771AC-1PH	14.38	8.86	3.55	22.00	6.75	6.31	5.70	2.16	.34
4771AC-1PH2	14.38	8.86	3.55	21.00	6.75	6.31	5.70	2.16	.34
4771AC-3PH	14.38	8.86	3.55	19.00	6.75	6.31	5.70	2.16	.34
4771DC	14.38	8.86	3.55	18.69	6.75	6.31	5.70	2.16	.34
4771PN	14.38	8.86	3.55	14.94	6.75	6.31	5.70	2.16	.34
4771HY	14.38	8.86	3.55	11.84	6.75	6.31	5.70	2.16	.34
4777	14.38	8.86	3.49	17.45	6.75	6.31	5.70	2.16	.34
4777DC	14.38	8.86	3.49	18.69	6.75	6.31	5.70	2.16	.34

Dimensions are for reference only and subject to change without notice.

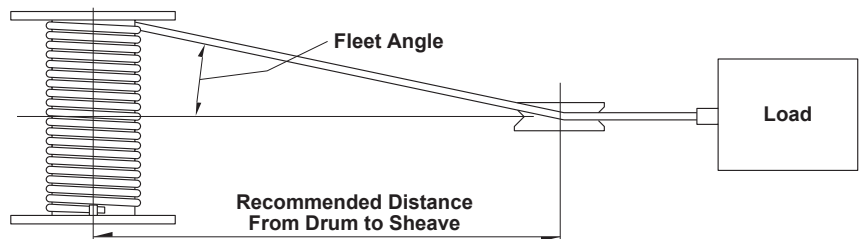

Series 477 – Drum Dimensions

model extension	drum diameter	flange diameter	drum width	fleet angle distance ¹
4771	3.00 in	6.00 in	6.00 in	10 ft
4771AC-1PH	3.00 in	6.00 in	6.00 in	10 ft
4771AC-1PH2	3.00 in	6.00 in	6.00 in	10 ft
4771AC-3PH	3.00 in	6.00 in	6.00 in	10 ft
4771DC	3.00 in	6.00 in	6.00 in	10 ft
4771PN	3.00 in	6.00 in	6.00 in	10 ft
4771HY	3.00 in	6.00 in	6.00 in	10 ft
4777	3.00 in	6.00 in	4.00 in	7 ft
4777DC	3.00 in	6.00 in	4.00 in	7 ft

Dimensions are for reference only and subject to change without notice.

¹ Recommended minimum distance between drum and lead sheave for smooth drum.

Important:

It is the owner's or operator's responsibility to determine the suitability of the equipment to its intended use. Study all applicable codes, manuals, and regulations. Be sure to read the Owner's Manual supplied with the equipment before operating it.